



UWL REPOSITORY

repository.uwl.ac.uk

Steel reinforced self-compacting concrete (SCC) cantilever beams: bond behaviour in poor condition zones

Montaser, Wael, Shaaban, Ibrahim ORCID logo ORCID: <https://orcid.org/0000-0003-4051-341X>, Rizzuto, Joseph, Zaher, Amr, Rashad, Ahmed and El Sadany, Shorouk (2023) Steel reinforced self-compacting concrete (SCC) cantilever beams: bond behaviour in poor condition zones. International Journal of Concrete Structures and Materials. ISSN 1976-0485

<http://dx.doi.org/10.1186/s40069-023-00581-9>

This is the Accepted Version of the final output.

UWL repository link: <https://repository.uwl.ac.uk/id/eprint/9725/>

Alternative formats: If you require this document in an alternative format, please contact: open.research@uwl.ac.uk

Copyright: Creative Commons: Attribution 4.0

Copyright and moral rights for the publications made accessible in the public portal are retained by the authors and/or other copyright owners and it is a condition of accessing publications that users recognise and abide by the legal requirements associated with these rights.

Take down policy: If you believe that this document breaches copyright, please contact us at open.research@uwl.ac.uk providing details, and we will remove access to the work immediately and investigate your claim.

Rights Retention Statement:

International Journal of Concrete Structures and Materials

Steel Reinforced Self-Compacting Concrete (SCC) Cantilever Beams: Bond Behaviour in Poor Condition zones

--Manuscript Draft--

Manuscript Number:	CSTR-D-22-00124R2
Full Title:	Steel Reinforced Self-Compacting Concrete (SCC) Cantilever Beams: Bond Behaviour in Poor Condition zones
Article Type:	Research
Funding Information:	
Abstract:	<p>Previous investigations carried out on reinforced self-compacted concrete (SCC) beams have reported contradictory results on reinforcement bond behaviour occurring in the zones defined for good bond conditions according to Eurocode2. Cantilevered SCC beams' critical upper tension reinforcement bond behaviour has previously had limited reporting. In this study, the bond behaviour in normally vibrated concrete (NVC) and self-compacted concrete (SCC) in poor condition s zones are compared and the differences are highlighted. The effect of four parameters , including (i) concrete type (SCC and NVC), (ii) characteristic strength of SCC, (iii) lap splice length, and (iv) depth of concrete cover for the reinforcement is investigated. It was found that for the studied beams, increasing splice length improved the energy absorption and changed the failure mode to a more ductile manner even at the poor bond conditions zones. The maximum measured steel strains in SCC beams in the lap splice zones, were higher than those for NVC specimens. The mean bond stress values, for SCC beams with 25% and 50% lap splice lengths, were higher than those of NVC beams, with the same lap splice lengths, by 16% and 13%, respectively. The results of the current study showed that the empirical equations from the literature overestimated the bond strength of the splice lap length for cantilever upper steel in SCC beams with long splices which agrees with the state of the art as these equations were developed originally for short anchorage lengths.</p>
Corresponding Author:	Wael Montaser, Associate Professor October 6 University Giza, EGYPT
Corresponding Author E-Mail:	wmontaser.eng@o6u.edu.eg
Corresponding Author Secondary Information:	
Corresponding Author's Institution:	October 6 University
Corresponding Author's Secondary Institution:	
First Author:	Wael Montaser, Associate Professor
First Author Secondary Information:	
Order of Authors:	<p>Wael Montaser, Associate Professor</p> <p>Ibrahim Shaaban, professor</p> <p>Joseph Rizzuto, Professor</p> <p>Amr Zaher, professor</p> <p>Ahmed Rashad, Associate professor</p> <p>Shorouk El Sadany, Assistant Lecturer</p>
Order of Authors Secondary Information:	
Response to Reviewers:	The necessary explanations provided in the authors replies are incorporated in the paper as indicated in the attached table:
Additional Information:	

Question	Response
----------	----------

[Click here to view linked References](#)

Steel Reinforced Self-Compacting Concrete (SCC) Cantilever Beams: Bond Behaviour in Poor Condition Zones

Wael Mohamed Montaser¹, Ibrahim Galal Shaaban², Joseph P. Rizzuto³, Amr Hussein Zaher⁴,
Ahmed Rashad⁵, and Shorouk Mohamed El Sadany⁶

¹ Construction and Building Department, Faculty of Engineering, October 6 University, Giza, Egypt.

Email: wmontaser.eng@o6u.edu.eg

² School of Computing and Engineering, University of West London, St Mary's Road, Ealing, London W5 5RF.

Email: ibrahim.shaaban@uwl.ac.uk

³ School of Computing and Engineering, University of West London, St Mary's Road, Ealing, London W5 5RF.

Email: j.rizzuto@uwl.ac.uk

⁴ Structural Engineering Department, Faculty of Engineering, Ain Shams University, Cairo Egypt.

Email: amr_zaher@eng.asu.edu.eg

⁵ Structural Engineering Department, Faculty of Engineering, Ain Shams University, Cairo Egypt.

Email: ahmedrashad1973.ar@gmail.com

⁶ Construction and Building Department, Faculty of Engineering, October 6 University, Giza, Egypt.

Email: shorouk.elsadany.eng@o6u.edu.eg

1
2
3
4
5
6
7
8
9
10
11
12
13
14
15
16
17
18
19
20
21
22
23
24
25
26
27
28
29
30
31
32
33
34
35
36
37
38
39
40
41
42
43
44
45
46
47
48
49
50
51
52
53
54
55
56
57
58
59
60
61
62
63
64
65

1
2
3
4 **Abstract**
5

6
7 Previous investigations carried out on reinforced self-compacted concrete (SCC) beams have
8 reported contradictory results on reinforcement bond behaviour occurring in the zones defined for
9 good bond conditions according to Eurocode2. Cantilevered SCC beams' critical upper tension
10 reinforcement bond behaviour has previously had limited reporting. In this study, the bond
11 behaviour in normally vibrated concrete (NVC) and self-compacted concrete (SCC) in poor
12 conditions zones are compared and the differences are highlighted. The effect of four parameters,
13 including (i) concrete type (SCC and NVC), (ii) characteristic strength of SCC, (iii) lap splice
14 length, and (iv) depth of concrete cover for the reinforcement is investigated. It was found that
15 for the studied beams, increasing splice length improved the energy absorption and changed the
16 failure mode to a more ductile manner even at the poor bond conditions zones. The maximum
17 measured steel strains in SCC beams in the lap splice zones, were higher than those for NVC
18 specimens. The mean bond stress values, for SCC beams with 25% and 50% lap splice lengths,
19 were higher than those of NVC beams, with the same lap splice lengths, by 16% and 13%,
20 respectively. The results of the current study showed that the empirical equations from the
21 literature overestimated the bond strength of the splice lap length for cantilever upper steel in
22 SCC beams with long splices which agrees with the state of the art as these equations were
23 developed originally for short anchorage lengths.
24
25
26
27
28
29
30
31
32
33
34
35
36
37
38
39
40
41
42
43
44
45
46
47

48
49 **Keywords:**
50

51
52 Self-compacting concrete; bond strength; bond stress; lap length of steel bars in tension; empirical
53 equations; concrete cover; poor bond conditions.
54
55
56
57
58
59
60
61
62
63
64
65

Nomenclature

$A_{s_{req}}, A_{s_{prov}}$ = Area of reinforcement required and provided at that section

α (1 to 5) = Set of coefficients as given in Table 5.2 [33]

$l_{b, rqd}$ = The basic required anchorage length

$$l_{b, rqd} = (\Phi / 4) \cdot (\sigma_{sd} / f_{bd})$$

l_{bd} = The anchorage length (according to EC2 [22]).

L_d = The anchorage length (according to ECP 203-2018 [23]).

σ_{sd} = The maximum value of the design steel stress

α = Straight bars in Tension = 1.0

β = ST. 400/600 - in Tension = 0.75

η = Top Reinforcement = 1.3

$$f_{bu} = 0.3 \sqrt{\frac{f_{ck, cube}}{\gamma_c}}$$

f_{bd} = Ultimate bond stress

u = Bond stress

U = Bond force per unit length

\sum_0 = Sum of the perimeters of the bars developed at a section

A_b = Area of an individual bar or wire

f_s = Tensile stress in reinforcement

E_s = The modulus of elasticity which equals 203,000 N/mm²

1
2
3
4
5 ε_s = The measured steel strains
6

7 f_{ult} = Ultimate tensile stress in reinforcement
8

9
10 f_y = Yield stress in steel reinforcement
11

12 ε_{ult} = Ultimate strains in steel reinforcement
13

14
15 ε_y = Yield strain in steel reinforcement
16

17 U_u = Bond strength of bars
18

19
20 u = Mean bond stress
21

22 c = The minimum clear concrete cover
23

24 Δ_{max} = Maximum deflection at specific location
25

26
27 d_b = Bar diameter
28

29
30 f_{ck} = The cylinder compressive strength of concrete.
31

32
33 $f_{ck, cube}$ = The cube compressive strength of concrete = 1.2-1.23 f_{ck} (Chapter 3, EC-2 [22])
34
35
36

37 **1. Introduction**

38

39
40 The use of self-compacting concrete (SCC) has been rapidly increasing for the past three decades.
41

42 SCC is now widely used in many types of structures. A notable example of SCC use is in the
43 anchorage blocks of the Akashi Kaikyo suspension bridge which opened in 1998 [1].
44
45
46

47
48 The bond between concrete and reinforcing bars in splices is an essential requirement in the
49 design of reinforced concrete (RC) structures [2]. This has an important effect on the behaviour
50 of reinforced concrete elements during the cracked stage [2]. Deflections are influenced by the
51 bond stress distribution along the reinforcement bars and by the slippage between the bars and the
52 surrounding concrete [3]. Various studies have been conducted on SCC bonding [4]. The outcomes
53
54
55
56
57
58
59
60
61
62
63
64
65

1
2
3
4 of these studies appear contradictory. Some researchers indicate that the bond stress between
5
6 reinforcing steel bars and SCC are higher than that between reinforcing bars and normally vibrated
7
8 concrete (NVC) [5, 6, and 7]. Others have reported either no differences between these types of
9
10 concrete or lower bond stresses with SCC [8, 9, 10, and 11]. The European Guidelines for self-
11
12 compacting concrete [12] represents a state-of-the-art report used by designers, purchasers,
13
14 specifiers, producers and other stake holders.
15
16
17
18

19 20 **2. Literature Review**

21
22
23 Chan *et al* [4] studied the bond between concrete and steel reinforcements for SCC and ordinary
24
25 concrete. Their results showed that SCC members had higher reinforcing bar bond than those
26
27 exhibited in ordinary concrete. It was also found that the reduction in bond due to bleeding and
28
29 heterogeneous nature, in the case of ordinary concrete, did not take place with SCC.
30
31

32
33 Pandurangan *et al.* [5] tested beam specimens of dimensions (200 mm wide x 250 mm deep x
34
35 2200 mm long) to study the effect of using SCC on the bond strength and mode of bond failure of
36
37 tension lap splices anchored in NVC. Each beam was arranged with spliced bars in a region at
38
39 mid-span where constant moment occurred and various levels of stirrup confinement were in place
40
41 [5]. They agreed with Chan *et al* [4] that there was an increase in the bond strength when SCC
42
43 was used. They found also that ductility and splice strength increased as the confinement increase.
44
45 In addition, the failure in the splice region took place as a result of yielding of the steel when the
46
47 stirrup spacing was less than 150 mm [5].
48
49
50
51

52
53 Kaihua Liu *et al* [13] investigated the bond behaviour of deformed steel bars in SCC and NVC.
54
55 Thirty-three cube specimens (with 150 mm sides and embedded steel bars) with different concrete
56
57 compressive strengths, different concrete cover sizes of (2 d_b , 3 d_b , 4.2 d_b , and 5 d_b), and
58
59
60
61
62
63
64
65

1
2
3
4 embedded lengths (3 d_b , 4 d_b , 5 d_b , and 6 d_b) were prepared and tested under pull-out loading.
5
6 They found that the bond strength between reinforcing bars and SCC increased with increasing
7
8 concrete strengths and concrete cover depth [13]. Specimens with shorter embedded length
9
10 showed higher bond strength [13]. They concluded that deeper concrete covers and an increase in
11
12 the transverse reinforcement can provide effective restraint and changes to the failure pattern from
13
14 splitting failure to pull-out failure [13]. They also found that the existing empirical and code
15
16 models in the literature for bond strength prediction in NVC were all conservative and could be
17
18 extended to SCC [13].
19
20
21
22
23

24 Turk *et al* [14] tested twelve beam specimens of (2000 mm long x 300 mm deep x 200 mm wide)
25
26 in bending to study the effect of SCC and the diameter of reinforcement on bond-slip of tension
27
28 lap-splices. Test variables were concrete type (SCC and NVC) and reinforcing bar size (16 mm
29
30 and 20 mm) [14]. They found that increasing the diameter of the steel bar from 16 to 20 mm
31
32 decreases the bond strength, and the normalised bond strengths of the SCC mixes were higher
33
34 than those of the NC mixes by 4% only [14].
35
36
37
38

39 El-Azab *et al* [15] tested sixteen simply supported beams. These were divided into four groups.
40
41 All beams were of (1800 mm span and 200 mm wide x 400 mm deep) cross-section cast with high
42
43 strength self-consolidated concrete (HSSCC) [15]. Twelve beams contained splice-laps and these
44
45 were located in the constant moment zone. Four beams without splices were used as control
46
47 beams [15]. Their results showed that the splice length of 40 bar diameters was the minimum to be
48
49 taken as a sufficient splice length, as the beams started to show signs of cracking and failed at a
50
51 load equal to or higher than those without splices [15]. In addition, it was found that using a larger
52
53 number of steel bars with smaller bar diameter increased both the beam ultimate capacity and
54
55 ductility [15].
56
57
58
59
60
61
62
63
64
65

1
2
3
4 Wu *et al.* [16] investigated the lap splice bond strength in tension in NVC and SCC beams. Six
5
6 beam specimens were cast and subjected to bending. They stated that the SCC and NVC beams
7
8 presented similar bond strengths. In addition, both SCC and NVC beams with transverse stirrups
9
10 had ductile flexural behaviour in the area of tension laps [16]. They observed minor spalling
11
12 between reinforcing steel and concrete under service loading [16].
13
14

15
16
17 Almeida *et al* [17] studied the mechanical properties (compressive strength, modulus of elasticity
18
19 and tensile strength) and bond strength of SCC by testing concrete cylinders (150 mm dia. x 300
20
21 mm deep) of 50 N/mm² compressive strength at 28 days. The studied variables were: (i)
22
23 maximum aggregate size and (ii) SCC fluidity (concrete of very high workability using
24
25 superplasticizer) [17]. They concluded that the variability of the SCC was small for the modulus
26
27 of elasticity and for the compressive strength, but the tensile strength presented a significant
28
29 variability due to the failure mode [17]. In addition, the variability of the bond strength was small
30
31 which indicated the reliability of SCC in the civil construction [17].
32
33
34

35
36
37 Zuo *et al* [18] experimentally tested sixty-four specimens to study the effects of concrete
38
39 properties on the splice strength of high relative strengths, ranging from 29 to 108 N/mm². They
40
41 found that concrete containing stronger coarse aggregate had higher splice strength under different
42
43 confinement conditions [18]. In addition, for splices confined by transverse reinforcement, the
44
45 contribution of transverse reinforcement to splice strength increased with the increase of coarse
46
47 aggregate content in concrete [18]. Moreover, the splice strength of bars confined by transverse
48
49 reinforcement increased, with an increase in relative rib area and bar diameter [18].
50
51
52

53
54 Zhao *et al* [19] investigated bond behaviorus of FRP bars in ECC experimentally and numerically.
55
56 A simplified bond failure model was established based on the pullout failure mode. Results
57
58 indicated that increasing the ECC strength led to a proportional increase in the bond strength and
59
60
61
62
63
64
65

1
2
3
4 rebar with higher ribs exhibited higher bond strengths (by a maximum of 55%) than counterparts
5
6 with lower ribs
7

8
9
10 Zhao *et al* [20] Studied the mechanical properties of steel-FRP composite SFCBs bars under
11
12 tensile tests. Bond performance of SFCBs in concrete were tested. Results showed that SFCBs
13
14 had bond strengths between round and ribbed rebar and the rebar diameter and surface treatment
15
16 are key factors influencing the bond strength of SFCB-concrete interface [20]. The bond-slip
17
18 behaviour of SFCB-concrete specimens can be predicted by improving the bonding models of
19
20 FRP bars [20].
21
22

23
24
25 In the section above, the bond strength of steel reinforcement bars and tension lap splices of
26
27 steel bars embedded in concrete were reviewed for NVC and SCC beams. All the test results
28
29 cited in the literature were on the effect of SCC on bond strength for lap splices of tensile
30
31 steel reinforcement in regions supporting sagging moments where the bond conditions were
32
33 good (See Figure 1). Very limited studies were cited on top steel in cantilever SCC beams
34
35 [21].
36
37

38 39 40 **3. Research significance** 41

42
43 The bond behaviour of lap splices of tensile steel bars in SCC beams in regions supporting
44
45 hogging moments (where bond conditions are poor) may exhibit different behavior due to the
46
47 variable depth of the concrete over the rebar as a result of using non-vibrated self-
48
49 consolidating concrete. Figure 1 illustrates the top reinforcement in beams located in poor
50
51 bond zones given in Eurocode 2 [22]. This research will study the effect of SCC on the bond
52
53 behaviour of the lap splices at poor bond conditions zones typically found as the top
54
55 reinforcement in cantilevered beams within a zone where the beam section is subjected to
56
57
58
59
60
61
62
63
64
65

1
2
3
4 shear and bending. The variables considered include (i) concrete type (SCC and NVC), (ii)
5
6 **characteristic strength (cube concrete compressive strengths at 28 days)** of SCC, (iii) lap splice
7
8 length, and (iv) depth of concrete cover measured from the c.g of the bar to top concrete surface.
9

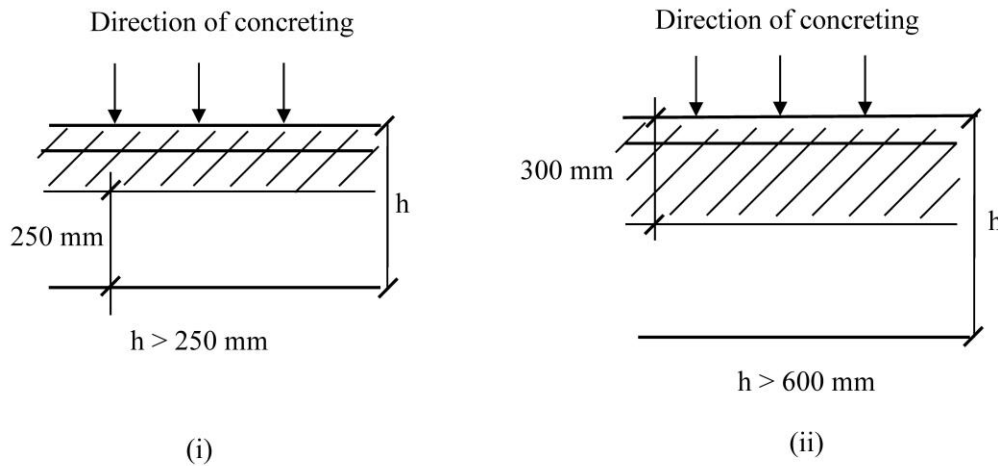

(i) Good bond conditions in the unhatched zone, and (ii) poor bond conditions in the hatched zone.

Figure 1 Good and poor bond zones according to EC2 [22]

4. Experimental Work

This study considered nine simply supported beam specimens that were statically tested under two-point loads. One end was cantilevered, and different reinforcing configurations were detailed as shown in Figures 2-4. The objectives of the test program were as follows:

1- Study the rebar bond behaviour during bending failure at the maximum negative (hogging) moment occurring over the cantilever support.

2- Evaluate lap splice efficiency according to Eurocode2 [22] and ECP 203-2018 [23] using both SCC and NVC.

1
2
3
4 3- Evaluate the applicability and accuracy of available empirical equations to predict lap splices
5
6 for SCC beams.
7
8
9

10 **4.1 Test Specimens**

11
12
13 The nine beams of rectangular cross-section specimens were composed of NVC (used for
14 comparison purposes), normal strength SCC and high-strength SCC. These beams were divided
15 into three groups. The dimensions of beams were: (300 mm deep x 200 mm wide x 2700 mm
16 long). Figure 2 shows (a) the electrical strain gauges attached to the steel reinforcement in the
17 splice zone, (b) a reinforcement cage and (c) casting of a typical test beam specimen. (d) Curing
18 of specimens using wet burlap. Figure 3 shows the dimensions and geometry of the test
19 specimens. It can be seen from the figure that only one sample was devoted for the study of
20 concrete cover in order to focus on the other parameters studied in this research. Table 1 provides
21 the test specimen beam details including groups, mixes, and lap splice length rebar details. It is
22 worth mentioning that the lap splice length was taken as a percentage of anchorage length, L_d ,
23 which was measured according to Eurocode2 [22] and ECP 203-2018 [23].
24
25
26
27
28
29
30
31
32
33
34
35
36
37
38
39
40
41
42
43
44
45
46
47
48
49
50
51
52
53
54
55
56
57
58
59
60
61
62
63
64
65

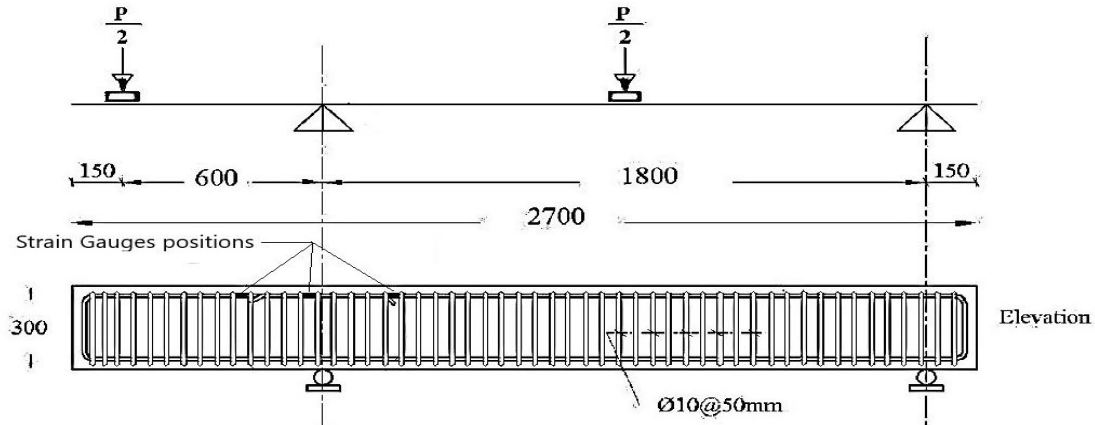

(a)



(b)



(c)



(d)

Figure 2 (a) Electrical strain gauges' locations, (b) and reinforcement cage, (c) casting a typical beam. (d) Curing of specimens

1
2
3
4
5
6
7
8
9
10
11
12
13
14
15
16
17
18
19
20
21
22
23
24
25
26
27
28
29
30
31
32
33
34
35
36
37
38
39
40
41
42
43
44
45
46
47
48
49
50
51
52
53
54
55
56
57
58
59
60
61
62
63
64
65

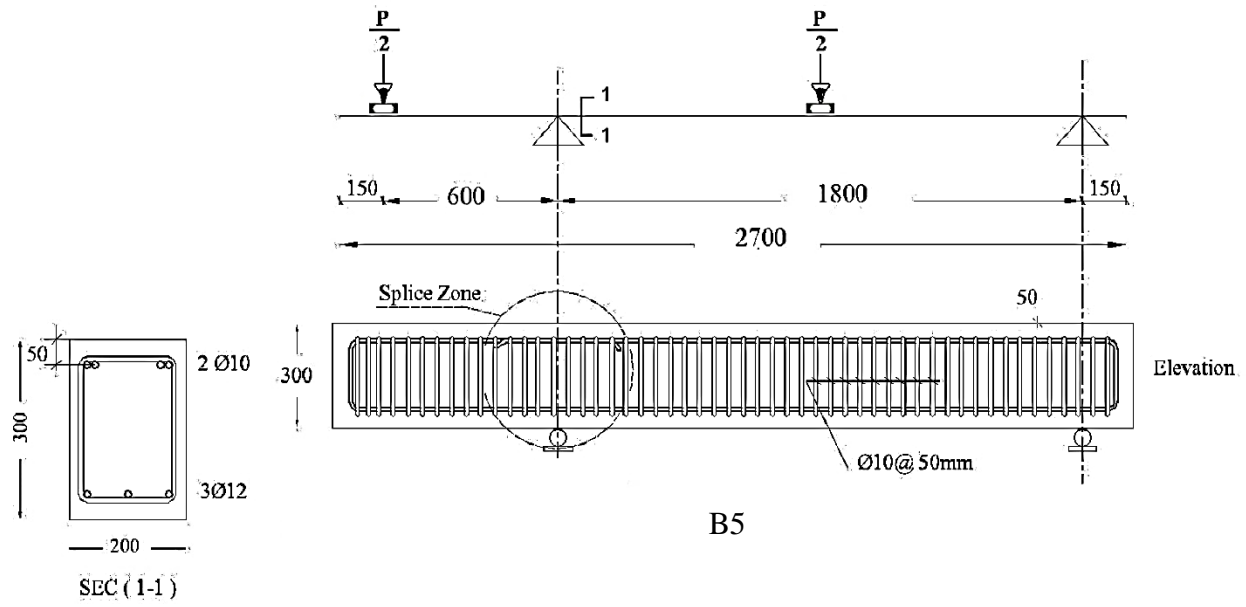
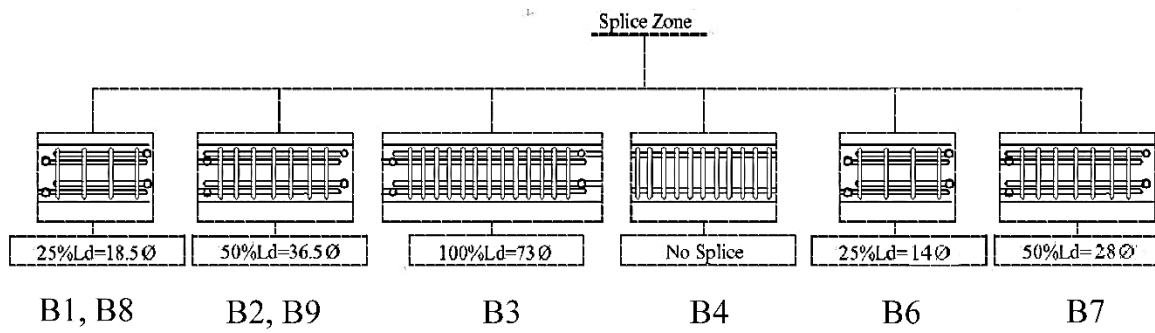
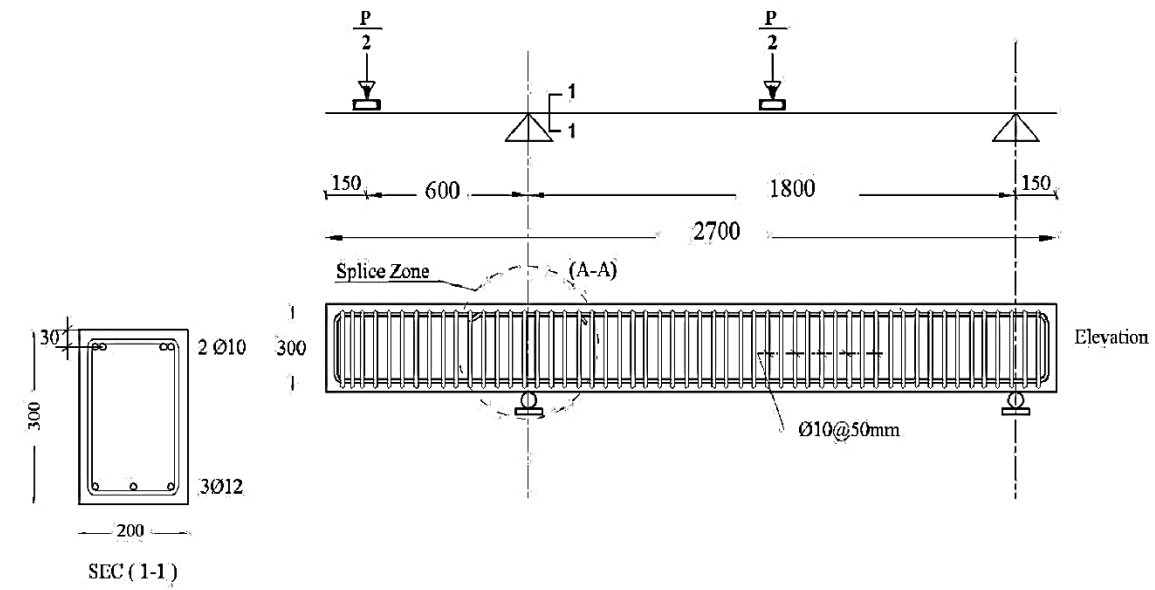

Figure 3 Geometry and dimensions of studied specimens

Table 1: Test specimens

Groups	Beam Number	Concrete type	Concrete strength, MPa, $f_{ck, cube}$	Concrete Cover, mm	Lap splice length	% of Lap splice length acc. to EC2 [20]	% of Lap splice length acc. to ECP [21]	Top steel rebar	Bottom steel rebar	Stirrup details in tested zone		
										Diameter, mm	Spacing, mm	f_y , N/mm ²
1	B1	SCC	35	30	18.5 ϕ	27% l_{bd}	25% L_d	2 ϕ 10	3 ϕ 12	ϕ 10	50	586
	B2				36.5 ϕ	54% l_{bd}	50% L_d					
	B3				73 ϕ	107% l_{bd}	100% L_d					
	B4				-	No splice	No splice					
	B5			50	18.5 ϕ	27% l_{bd}	25% L_d					
2	B6	SCC	65	30	14 ϕ	30% l_{bd}	25% L_d	2 ϕ 10	3 ϕ 12	ϕ 10	50	586
	B7				28 ϕ	60% l_{bd}	50% L_d					
3	B8	NVC	35	30	18.5 ϕ	27% l_{bd}	25% L_d	2 ϕ 10	3 ϕ 12	ϕ 10	50	586
	B9				36.5 ϕ	54% l_{bd}	50% L_d					

4.2 Materials

The SCC was designed according to EN 206 [24] [Concrete. Specification, performance, production, and conformity], considering strength development, density, strength and durability.

SCC may exhibit creep or plastic shrinkage more than ordinary concrete mixes because of the high content of limestone powder. As a result, these aspects should be considered when designing SCC. In addition, SCC concrete should be cured as early as possible. SCC workability was within the range of the consistency of SCC described in EN 206 [24]. Final quantities of one cubic metre of concrete are reported in Table 2. Fresh concrete properties are reported in Table 3.

All steel reinforcement used in this research was high strength deformed steel. Three specimens of each diameter were tested in the lab using Universal Testing Machine, 1000 KN capacity. The average yield stress and ultimate tensile stresses were 586 N/mm² and 719 N/mm² for the 10 mm diameter bars, and 563 N/mm² and 899 N/mm² for the 12 mm diameter bars, respectively.

The lap splice length values chosen for this research are 25%, 50% and 100 % from the anchorage length obtained from ECP 203-2018 [23] and 27%, 54%, 107% according to Eurocode2 [22].

The lap splice length values are reported in Table 1.

Table 2: Mixture proportions for SCC1, SCC2 and NVC (kg/m³)

Materials	SCC1, $f_{ck, cube} = 35$ N/mm ²	SCC2, $f_{ck, cube} = 65$ N/mm ²	NVC, $f_{ck, cube} = 35$ N/mm ²
Cement	380	427.5	350
Dolomite (4-15 mm)	616	508	547
Dolomite (15-19 mm)	264	285	650
Sand (0-4)	935	932	753
Mixing water	192.5	153	136.5
Silica fume	----	22.5	----
Limestone powder	112.5	----	----

*For SCC, a high-performance superplasticiser concrete admixture (Viscocrete-3425) was used, whereas a melamine sulfonate polymer-based ordinary water reducer (Sika Control 40) was used in the NVC mixture.

Table 3: Concrete properties

Test	Units	Mix no.		
		Mix 1	Mix 2	Mix 3
		SCC1	SCC2	NVC
Slump flow (EFNARC- SF2=660-750)	mm.	700	690	----
Slump flow (T ₅₀₀) (EFNARC-VS1= 2-5)	s	3.2	3.8	----
J - RING (EFNARC=0-10) or (<N.M.S)	mm.	3	3.4	----
Slump cone (ECP 203 – 2018 [23] =75-125)	mm.	----	----	100

4.3 Calculation of the Anchorage Length

The calculation of the anchorage length, l_{bd} , according to Eurocode 2 [22] is:

$$l_{bd} = \alpha_1, \alpha_2, \alpha_3, \alpha_4, \alpha_5 l_{b, reqd} A_{s, reqd} / A_{s, prov} \quad (1)$$

And the anchorage length values, L_d , were calculated as 68ϕ for $f_{ck} = 28.50 \text{ N/mm}^2$ ($f_{ck, cube} = 35 \text{ N/mm}^2$) and 46ϕ for $f_{ck} = 53.25 \text{ N/mm}^2$ ($f_{ck, cube} = 65 \text{ N/mm}^2$)

The calculation of the anchorage Length, L_d , according to ECP203-2018 [23] is:

$$L_d = \alpha \beta \eta \phi \frac{(F_y / \gamma_s)}{4 f_{bu}} \quad (2)$$

And the anchorage length values, L_d , were calculated as 73ϕ and 56ϕ for $f_{ck, cube} = 35 \text{ N/mm}^2$, and 65 N/mm^2 , respectively. For example, B6 and B7 have fcu of 65 N/mm^2 while the other specimens have fcu of 35 N/mm^2 . Therefore, the splice lengths of B6 and B7 were different from those of the other specimens.

4.4 Testing Instrumentation

A 400 kN capacity load cell was used to measure the load. Deflections were measured using four dial gauges at the locations shown in Figure 4. Steel strains across the lap zone were measured using electrical strain gauges. The strain gauges were installed at the beginning (glued to one bar, Location 1), middle (glued to two bars in the splice, Locations 2 and 3) and end of the splice (glued to one bar, Location 4) as shown in Figure 2. First cracking load and crack width were also measured using demec points shown in Figure 4. It is worth mentioning that the maximum deflection was measured at the location of applied load, end of the cantilever, D.G (1) as shown in

1
2
3
4 Figure 4, while the strain was measured at the middle, left side and at the right side of the lap
5
6
7 splice (four locations as shown in Figure 2).
8
9

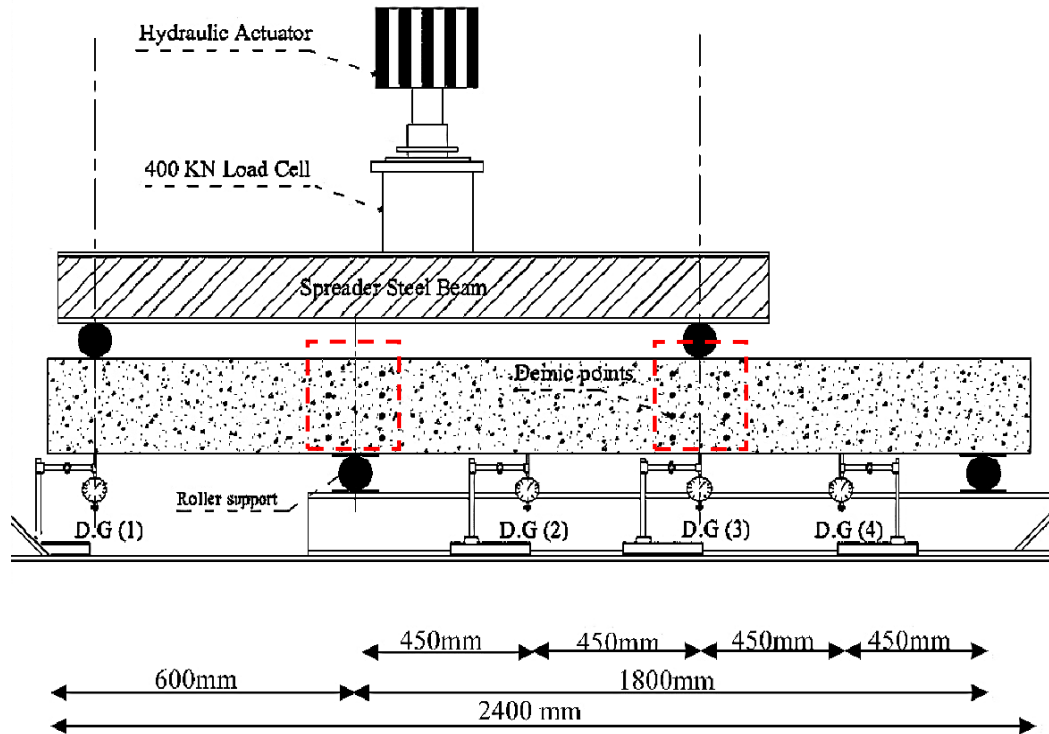

30
31
32
33
34
35
36 Figure 4 Test setup
37
38
39
40
41

42 4.5 Loading Procedure and Test setup

43
44
45 The test beams were tested under monotonic loading. They were configured in a four-point
46 bending test, as shown in Figure 4. Specimens were set over two rigid supports with an 1800 mm
47 simple span and a 600 mm cantilever span. A 300 kN hydraulic actuator was used to apply the
48 load. The load was divided into two concentrated loads separated by a distance of 1500 mm (one
49 at the cantilever free end and the other at the beam mid-span) and applied via a rigid steel
50 spreader I-beam. Data from the load cell, extensometer, dial gauges and strain gauges were
51 monitored and recorded.
52
53
54
55
56
57
58
59
60
61
62
63
64
65

5 Results and Discussion

5.1 Effect of Splice Lap Length

5.1.1 Crack pattern

The crack patterns for all test specimens are shown in [Figure 5](#). For beams B1, B2 and B3, defined in [Table 1](#), the first crack appeared vertically at the ends of lap-splice. These cracks were followed by cracks inside the lap zone as shown in [Figure 5](#). With an increase in loading, the horizontal cracks appeared in lap zone parallel to the top reinforcement; the vertical crack extended and started to widen eventually reaching the support. Failure occurred at a maximum moment with formation of vertical cracks in both sides of the beam. For the [Beam B4](#) reinforced with continuous bars without splice, a typical flexural vertical crack first appeared at the top of support in the maximum moment region, followed by cracks appearing vertically in both sides of center line of support.

5.1.2 Cracking and Ultimate Load capacity

The influence of the lap splice length, L_d on the cracking load was assessed and reported in [Table 4](#). For example, increasing the lap-splice length has increased the first cracking load from 30 kN for B1 to 35 kN for B2 and 40 kN for Beams B3 and B4. In addition, increasing the lap-splice length from 25% L_d to 100% L_d increased the maximum capacity by 36% as recorded in [Table 4](#).

Although Beam B3 has 100%, L_d , splice length, its ultimate load is less than that of B4 reinforced by continuous steel reinforcement without splice by approximately 13% as reported in [Table 4](#) and shown in [Figure 6](#). This may be attributed to the poor bond conditions at the upper steel for SCC.

1
2
3
4
5
6
7
8
9
10
11
12
13
14
15
16
17
18
19
20
21
22
23
24
25
26
27
28
29
30
31
32
33
34
35
36
37
38
39
40
41
42
43
44
45
46
47
48
49
50
51
52
53
54
55
56
57
58
59
60
61
62
63
64
65

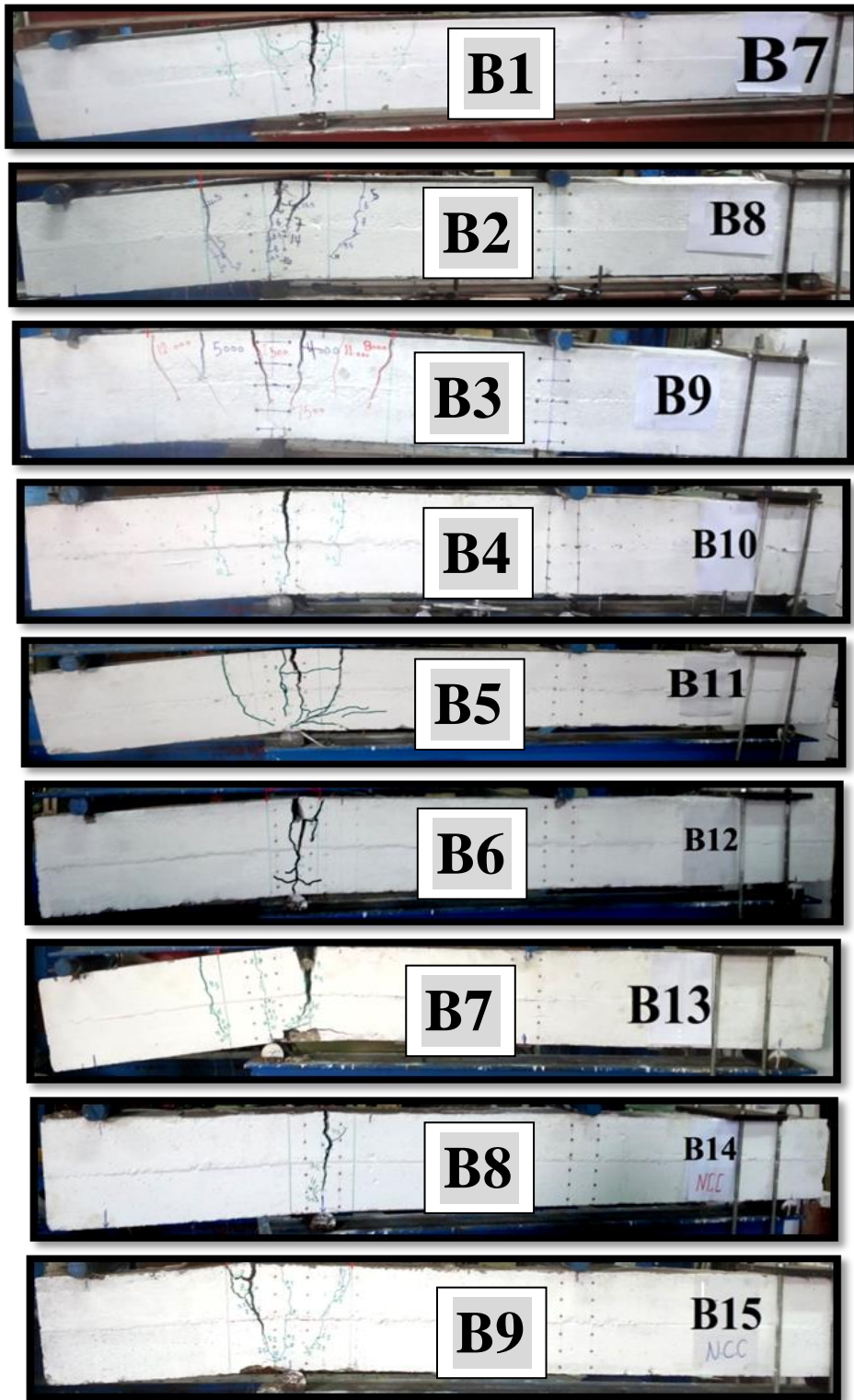

Figure 5 Crack patterns and failure loads

5.1.3 Load - deflection relationships and energy absorption

The deflection values under load conditions were measured at the locations indicated in [Figure 4](#).

Load-deflection curves of the Group 1 - SCC beams (B1 to B5) are shown in [Figure 6](#) for the deflections at location at D.G. (1) (see [Figure 4](#)). It can be seen from this figure that the area under load-deflection curves of Beam B3 with splice length ($100\% L_d$) is larger than that of Beam B4 reinforced by continuous steel without splice. It can be argued that the area of main steel reinforcement of B3 is higher than that of B4 with a full development length. Beam B2 of lap splice length, $50\% L_d$ exhibited similar behaviour as that of Beam B3 before cracking but had less moment capacity due to a shorter splice length. Beam B1 of splice length ($25\% L_d$) had the smallest area under the load-deflection curve compared to that of the other beams with same concrete cover in the same group. It is clear from the figure that increasing the lap length allows the beam to behave in a more ductile manner.

[Figure 7](#) show that the energy absorption (the area below the load-deflection curve) increased with increasing lap splice length. For example, Beam B3 had an energy absorption of 1144.22 kNmm². Also seen from [Figure 7](#) is that Beam B3 with a lap splice length equals $100\% L_d$, exhibited energy absorption higher than that of B4 reinforced by continuous steel bars without splices by 28%. This is again could be attributed to the larger area of steel reinforcement of B3 with full development length compared to that of B4.

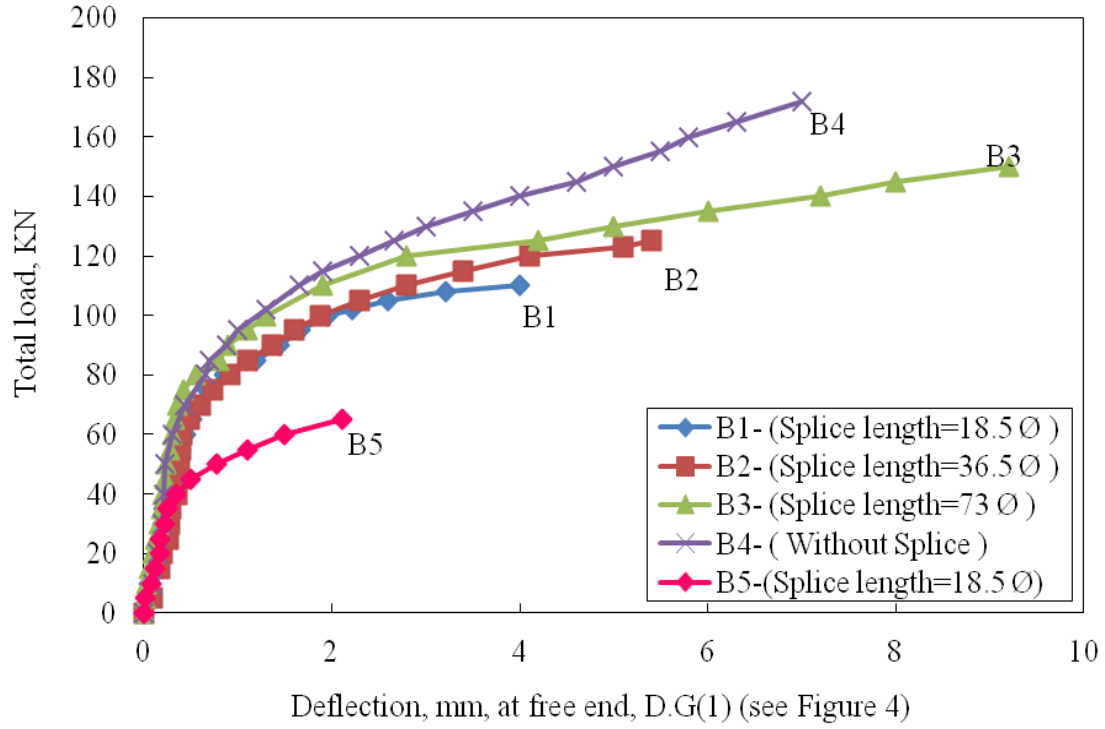

Figure 6 load-deflection curves for Group 1 (B1, B2, B3, B4, and B5)

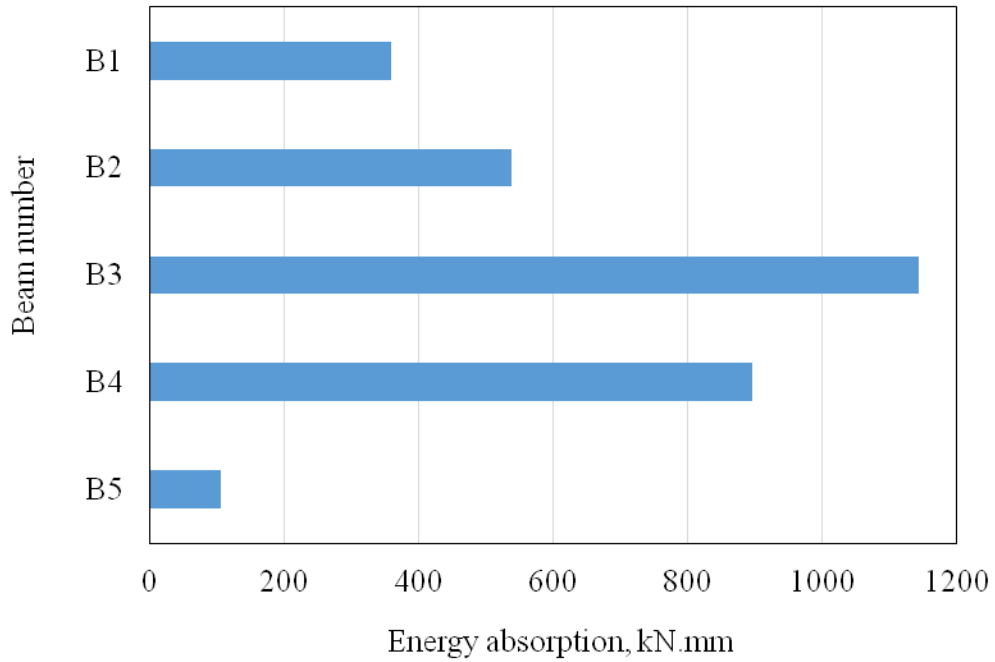

Figure 7 Energy absorption for Group 1

5.1.4 Bond stress at the splice

Bond stress is calculated according to ACI 318 [25] and ACI 408R-03 [26] equation:

$$u = \frac{U}{\Sigma_o} = \frac{\Delta T}{\Delta l \Sigma_o} = \frac{\Delta f_s A_b}{\Delta l \Sigma_o} = \frac{\Delta f_s A_b}{4 \Delta l} \quad (3)$$

Bournas et al [27] calculated the bond stress (u) distribution between spliced bars and the surrounding concrete using the following equation:

$$u = \left(\frac{d_b E_s}{4} \right) \left(\frac{\epsilon_s}{L_d} \right) \quad (4)$$

Bournas et al [27] reported that based on Eq. (4) and by assuming zero strain at the free ends of spliced bars, the bond strength distribution along the splice length, corresponding to peak lateral force, was computed.

Canbay et al [28] presented the ACI 318 [25] equation as follows:

$$U_u = \frac{f_s d_b}{4 L_d} \quad (5)$$

The stress in the steel, f_s , was determined from the maximum load and strain obtained for each beam specimen and was calculated based on elastic cracked section analysis ignoring the tensile stresses in the concrete in tension and considering linear stress-strain behaviour.

The mean bond stress values, u , are obtained by direct substitution in Equations 4 or 5 and are reported in Table 4. The mean bond stress values for different splice lengths for typical beams are shown in Figure 8. It can be seen from the figure that Beam B1 (splice length: 25% L_d) had the maximum bond stress. This demonstrates the effect of splice lap length on increasing the bond stress. The bond stress of Beams B2 (splice length: 50% L_d) and B3 (splice length: 100% L_d) were

approximately 56 % and 30 % of that of Beam B1. This may be attributed to the fact that L_d values of Specimens B2 and B3 are two times and four times that of B1.

Table 4: Results of the tested beams

Groups	(1)					(2)		(3)	
Beam Number	B1	B2	B3	B4	B5	B6	B7	B8	B9
Bar diameter (mm)	10					10		10	
Type	SCC					SCC		NVC	
$f_{ck, cube}$ (N/mm ²)	35					65		35	
Cover (mm)	30				50	30		30	
Lap splice length as percentage of anchorage length according to ECP 203-2018 [23]	25% L_d	50% L_d	100% L_d	No splice	25% L_d	25% L_d	50% L_d	25% L_d	50% L_d
Lap splice length (mm)	185	365	730	---	185	140	280	185	365
Confinement	ϕ 10@50 mm								
Cracking load, P, kN	30	35	40	40	20	40	45	30	35
Ultimate load, P, kN	110	125	150	172	65	135	160	80	115
Maximum deflection, Δ_{max} , mm, at D.G (1) (see Figure 4)	4.00	5.40	9.20	7	2.10	5.80	6.70	4.00	5.41
Ultimate strains, ϵ_{ult} (10^{-3}) at Location 1 (see Figure 2), E = 203,000 N/mm ²	2.44	2.72	2.93	2.93	2.11	2.93	2.93	2.13	2.45
f_{ult} , N/mm ² , calculated from the maximum load at ultimate strains, ϵ_{ult} , at Location 1, (see Figures 2, 9, 11, 17 and 23)	495	552	595	---	428	595	595	432	497
u , Mean bond stress, N/mm ² , (ACI-318) [25]	6.70	3.78	2.04	---	5.78	10.60	5.31	5.84	3.40
Failure mode	Bond			Flexure	Bond	Bond		Bond	

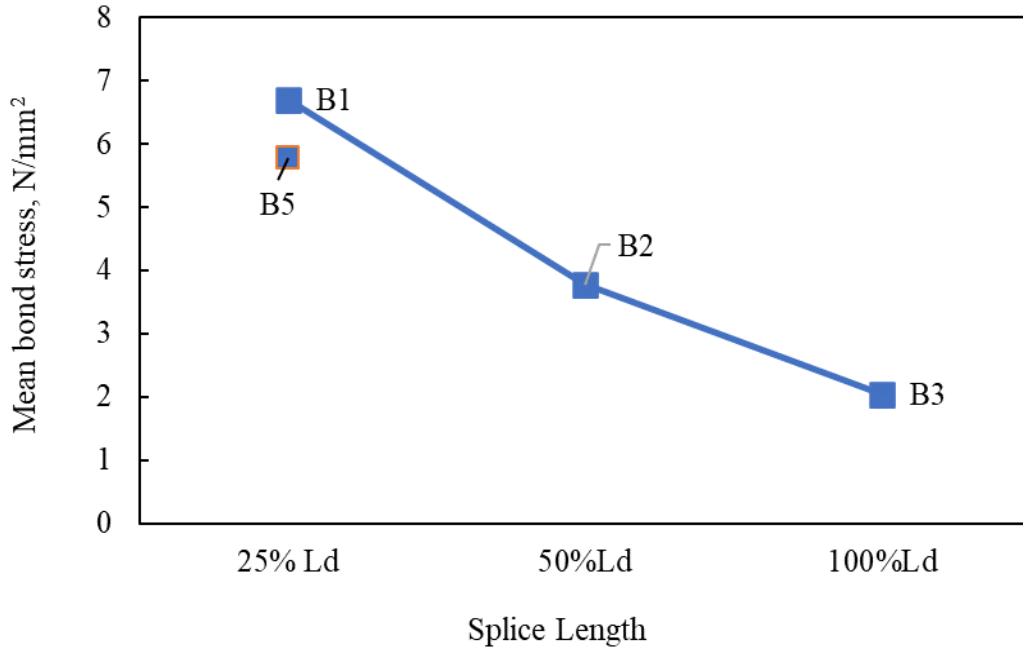
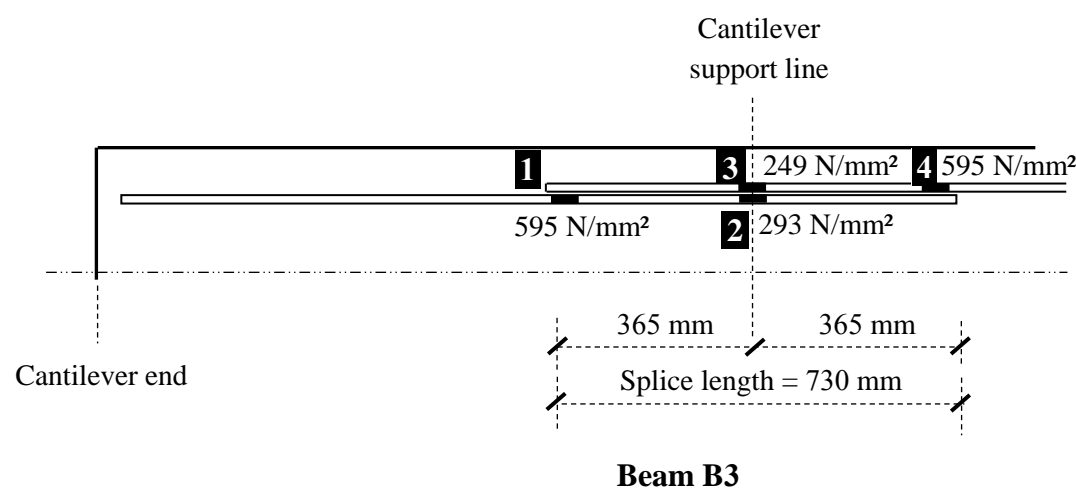
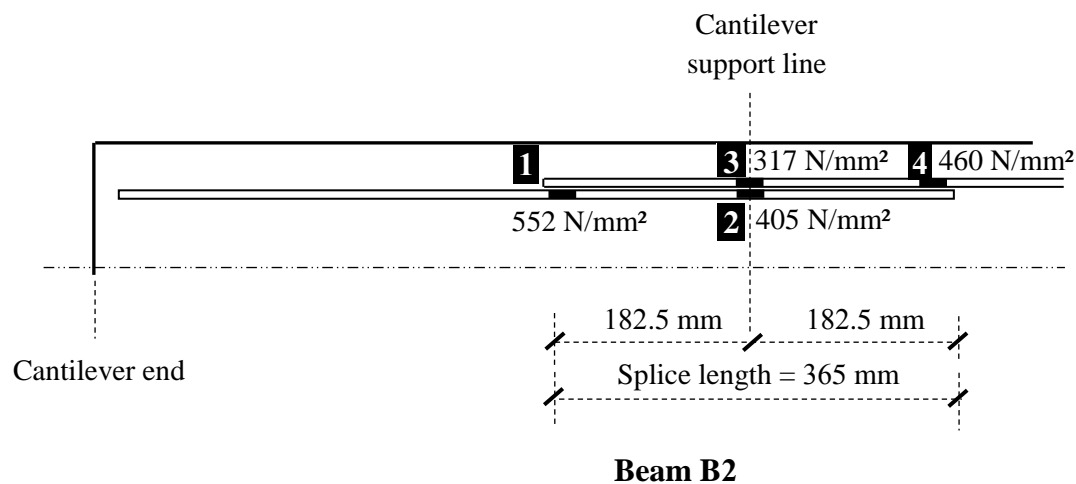
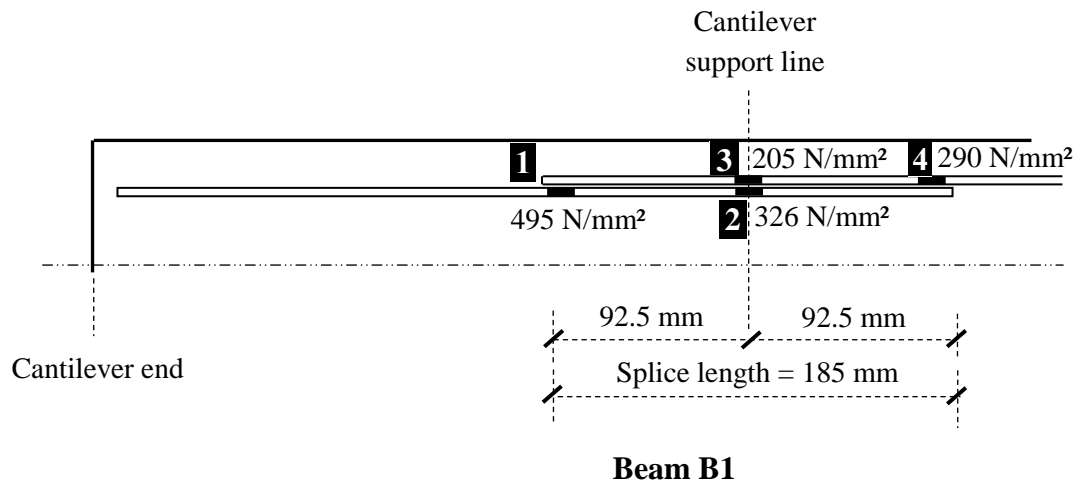

Figure 8 Bond stress for Beams B1, B2, B3, and B5 (at strain location 1, see Figure 2)

5.1.5 Ultimate steel stress values along the splice-length

Figure 9 shows that the ultimate values of the steel stress calculated along the splice length for a typical 10 mm diameter steel bar in Beams B1, B2 and B3 at different locations of the splice-lengths (see Figure2). The figure shows the calculated steel stresses along the splice length for 25% L_d , 50% L_d , and 100% L_d splice length. Increasing the splice length from 25% L_d to 50%, and to 100% L_d led to a rise in the steel stresses by approximately 12 % and 20 %, respectively. It can be argued that the moment in the upper steel in the shear zone is not constant and this may affect the stresses at the ends of the lap splices which may vary with the change of the lap length.



56 Figure 9 Ultimate steel stress values calculated from steel strains at strain gauges' locations
57 Values over 586 N/mm² indicate yielding. (Shear links omitted for clarity) Not to scale.
58
59
60
61
62
63
64
65

5.1.6 Load – steel strain relationships

The load strain relationships for longitudinal bars at splices in Specimens B1, B2, B3 and B4 are shown in Figure 10. It can be seen from the figure that the strain values did not exceed the yield value for high grade steel ($\epsilon_y = 586 \text{ N/mm}^2 / 203000 \text{ N/mm}^2 = 2887 \mu\text{strain}$) in beams B1 and B2. The recorded steel strains were similar for the beams indicated prior to cracking load, and after cracking until failure. The steel strain decreased with increasing splice length at the same load. This may be attributed to the reduction of stresses in steel bars at the splices as a result of increasing the splice-lengths.

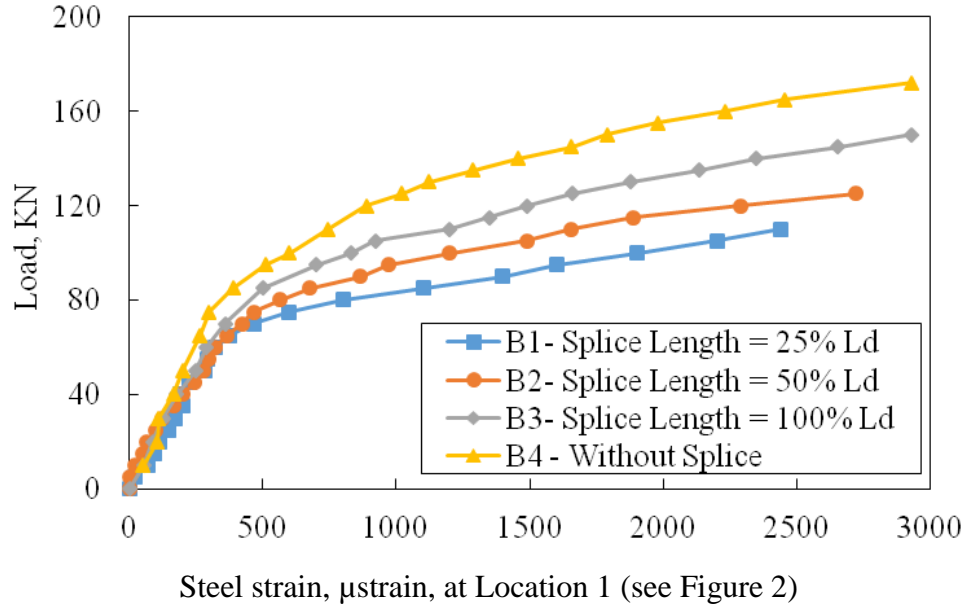

Figure 10 Load-longitudinal steel strain of Beams B1, B2, B3 and B4

5.2 Effect of Concrete Cover

5.2.1 Crack pattern

Figure 5 shows that increasing concrete cover led to increasing the widths of the cracks. It can be seen that Beam B5 with 50 mm concrete cover had more and larger cracks compared to those of

1
2
3
4 Beam B1 with concrete cover of 30mm. This may be attributed to the fact that the thicker cover
5
6 lowered the bars. This reduced the effective depth for the same curvature.
7
8
9

10 **5.2.2 Cracking and Ultimate Load capacity**

11
12 [Table 4](#) indicates that increasing concrete cover from 30 mm for B1 to 50mm for B5, resulted in a
13
14 reduction in the maximum capacity of B5 by 41%. In addition, increasing the concrete cover to
15
16 50mm for B5, led to a reduction of the first cracking load from 30 kN to 20 kN, respectively. This
17
18 may be attributed to the reduction of the effective depth in the section.
19
20
21
22

23 **5.2.3 Load - deflection curve and energy absorption**

24
25
26 [Figure 6](#) shows that the area below the load-deflection curve of Beam B5 with 50 mm concrete
27
28 cover was approximately 30% of that of Beam B1 having 30 mm concrete cover. This indicates
29
30 that Specimen B5 failed in a more brittle manner compared to that of B1. In addition, it can be
31
32 seen from [Figure 7](#) that Specimen B5 had a reduction of energy absorption by approximately 71%
33
34 compared to that of B1. This could be attributed to the fact that the effective depth of B5 was less
35
36 than that of B1 as a result of increasing the concrete cover and keeping the total thickness
37
38 constant.
39
40
41
42
43

44 **5.2.4 Bond stress at the splice**

45
46
47 [Figure 8](#) shows the bond stresses of Beams B1, B2, B3, and B5. As was stated in Section 5.1.4,
48
49 the bond stress reduces with the increase of the splice length. In addition, although B1 has the
50
51 same splice length as B5, bond stress in Beam B1 was higher than that of Beam B5 by 16 %. This
52
53 was because the increase in concrete cover while keeping the whole thickness of the beam
54
55
56
57
58
59
60
61
62
63
64
65

1
2
3
4 constant in B5 resulted in a reduction of the effective depth, and consequently, the reduction of
5
6 bond stress in its lap splices.
7
8
9

10 **5.2.5 Ultimate steel stress values along the splice length**

11
12
13 **Figure 11** shows the steel stress values of a steel reinforcement bar of 10 mm diameter for Beam
14
15 B5. The maximum stress at the left side of the lap-splice length was 428 N/mm^2 and reduces
16
17 towards the right side of the lap-splice length. It can be seen from the figure that the maximum
18
19 steel stress in Specimen B5 is less than that of Specimen B1 of the same L_d (see **Figure 9**) by
20
21 approximately 16%. This may be attributed again to what was explained above in Section 5.2.4
22
23 for the reduction of effective depth of Specimen B5.
24
25
26
27
28
29
30
31
32

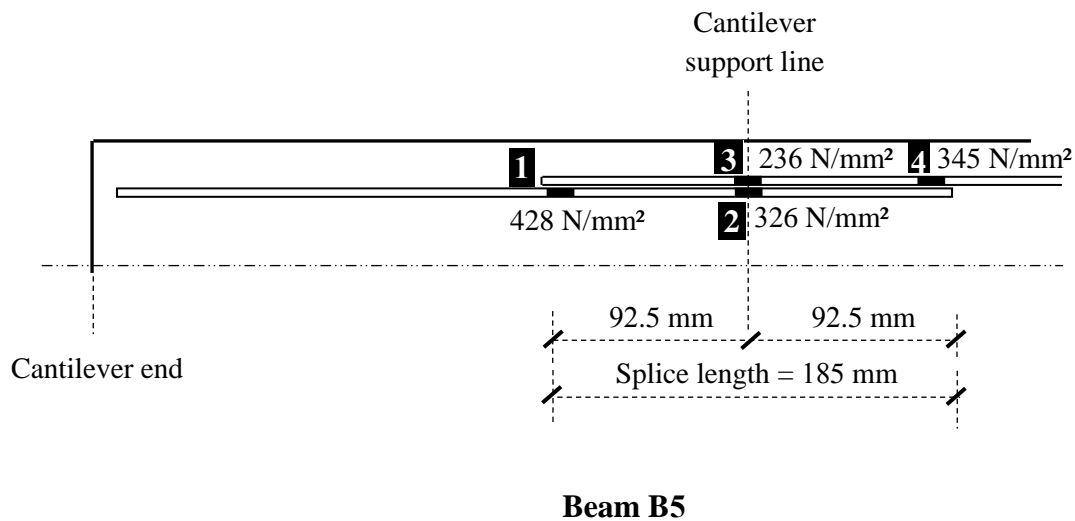

33
34
35
36
37
38
39
40
41
42
43
44
45
46
47 **Figure 11** Ultimate steel stress values calculated from steel strains at strain gauges' locations
48 shown in **Figure 2** (Shear links omitted for clarity) Not to scale.
49
50
51

52 **5.2.6 Load – steel strain curves**

53
54
55 The load-strain relationships for the longitudinal bars at splice locations in specimens B1 and B5
56
57 are shown in **Figure 12**. It can be seen from the figure that the strain values were all less than the
58
59 yield value for steel reinforcement ($2887 \mu\text{strain}$). The recorded steel strains for Specimen B5 are
60
61
62
63
64
65

1
2
3
4 less than those of Specimen B1. This reduction may be attributed to the change in effective depth
5
6 of the total section as a result of increasing the concrete cover for Beam B5.
7
8
9

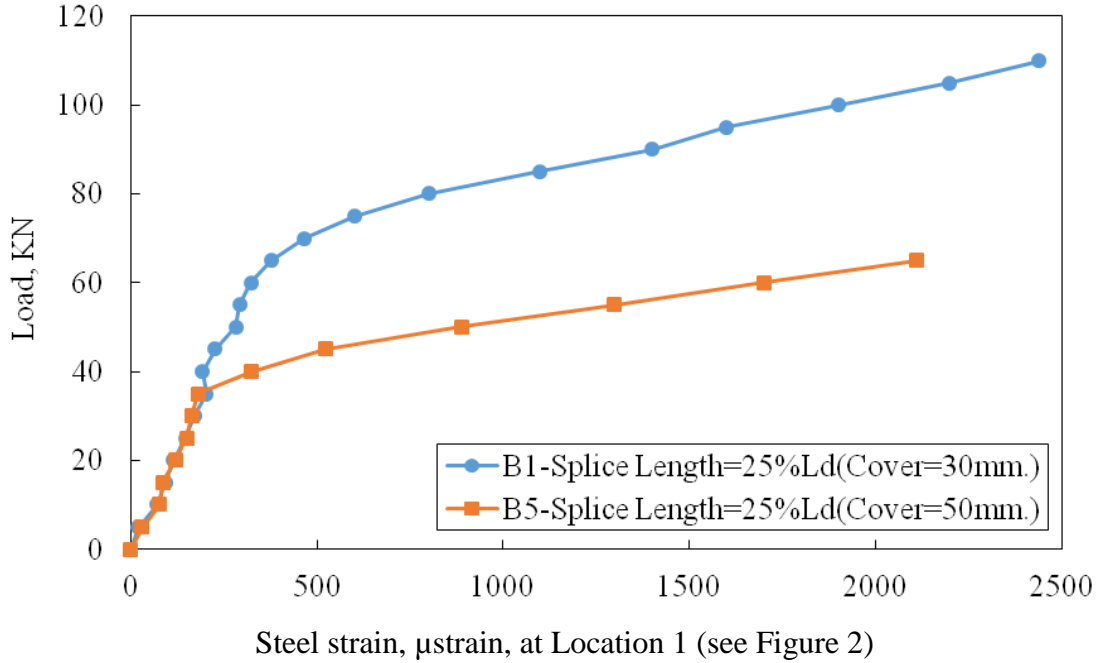

30
31
32
33 Figure 12 Load-longitudinal steel strain of Beams B1 and B5
34

35 36 5.3 Effect of the Concrete Compressive Strength

37 38 5.3.1 Crack pattern

39
40
41 The effect of compressive strength is shown in Figure 5 for Group 2 - SCC specimens (B6 and
42
43 B7) Table 1 shows these as having a compressive strength 65 N/mm^2 . Figure 5 shows the flexural
44
45 crack pattern for B6. The first crack developed in the vertical direction starting from the middle of
46
47 lap length. This was followed by cracks inside the lap zone. With increasing load, the cracks were
48
49 concentrated and widened at the middle of the lap splice only and extended to the support. Failure
50
51 occurred at the maximum moment with the formation of vertical crack on both sides of the beam.
52
53 Figure 5 also shows that Beam B7 had a typical first flexural crack pattern where the cracks
54
55 concentrated at lap splice ends only. These were followed by cracks inside the lap zone and
56
57
58
59
60
61
62
63
64
65

1
2
3
4 diagonal cracks near the support following increasing the load. Failure occurred with crushing at
5
6 the bottom cover at support. It can be observed from the figure that Specimens B6 and B7 behave
7
8 in a more brittle manner compared to Specimens B1 to B. It can be argued that the SCC of
9
10 specimens B6 and B7 had higher strength ($f_{ck, cube} = 65 \text{ N/mm}^2$) compared to that of the other test
11
12 specimens which they had normal strength SCC ($f_{ck, cube} = 35 \text{ N/mm}^2$).
13
14
15
16
17

18 **5.3.2 Cracking and Ultimate Load capacity**

19
20
21 From the recorded results in Table 4, increasing splice lap length in Group 2 Beams (B6 and B7)
22
23 led to an increase in the first cracking load. The first crack appeared at a load of 40 kN for Beam
24
25 B6 and 45 kN for Beam B7. It can be observed also from Table 4 also that increasing the length
26
27 of lap-splice from 25% L_d for B6 to 50% L_d for B7 resulted in an increase in the max capacity by
28
29 19%. Further, increasing the SCC compressive strength from 35 N/mm^2 for Group 1-SCC
30
31 specimens B1 and B2, to 65 N/mm^2 for Group 2-SCC specimens B6 and B7, led to an increase in
32
33 the maximum capacity by an average of 25%.
34
35
36
37
38

39 **5.3.3 Load - deflection curve and energy absorption**

40
41
42 Figure 13 shows load-deflection curves for beams B1, B2, B6, and B7. It can be seen from the
43
44 figure that the area under the curve for Beam B1 was approximately 58% of that of Beam B6.
45
46 This indicates that the ductility of Beam B1 was less than Beam B6. It can also be seen that the
47
48 area under the curve for Beam B2 was approximately 65% of that of Beam B7. This also indicates
49
50 that the ductility of Beam B2 was less than that of Beam B7. In addition, energy absorption for
51
52 Group 2 SCC specimens (B6 and B7) and B1 and B2 from Group 1 SCC beams are shown in
53
54 Figure 14. It can be seen from the figure that B6 and B7 with concrete compressive strength, f_{ck}
55
56
57
58
59
60 $_{cube} = 65 \text{ N/mm}^2$ had energy absorptions higher than those of beams with SCC compressive
61
62
63
64
65

strength, $f_{ck, cube} = 35 \text{ N/mm}^2$, B1 and B2 by 73% and 54%, respectively. This reduction in ductility for these beams may be attributed to the lower ultimate load as a result of using concrete with lower compressive strength.

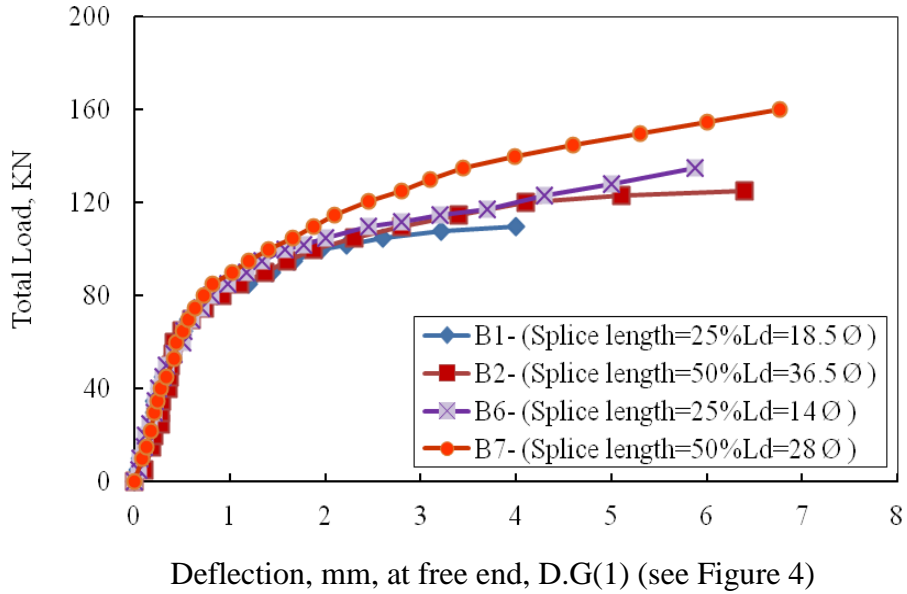

Figure 13 load-deflection curves for Beams B1, B2, B6 and B7

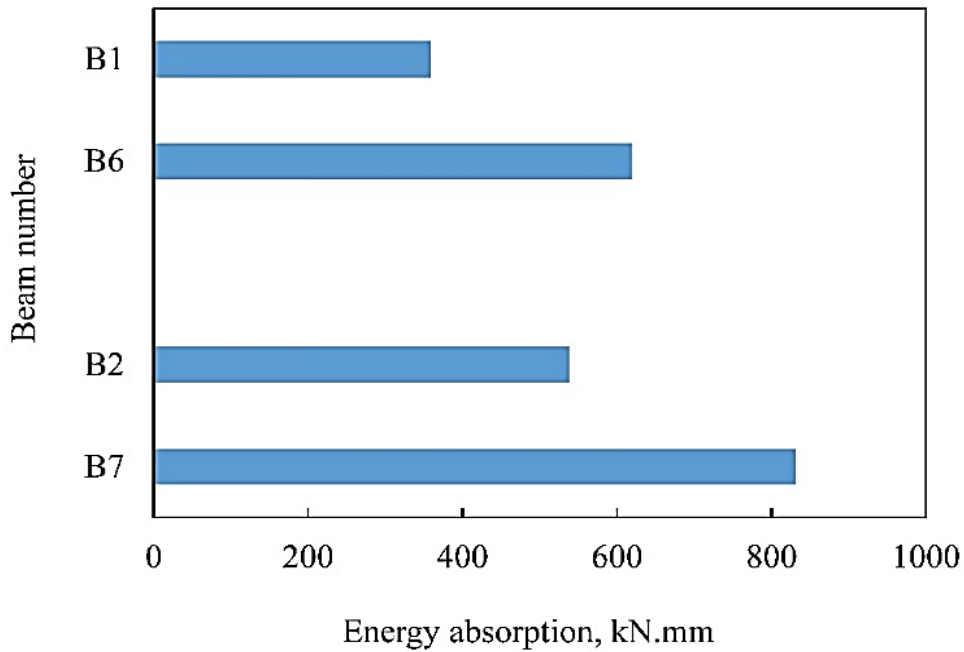

Figure 14 Energy absorption for Beams B1, B2, B6, and B7

5.3.4 Bond stress at the splice

The bond stress results for Beams B1, B2, B6, and B7 are shown in Figure 15. The mean bond stress values of Beams B1 and B2 were approximately 63 % and 71 % of those of Beams B6 and B7. This may be attributed to the lower concrete strength of Beams B1 and B2 compared to that of Beams B6, and B7.

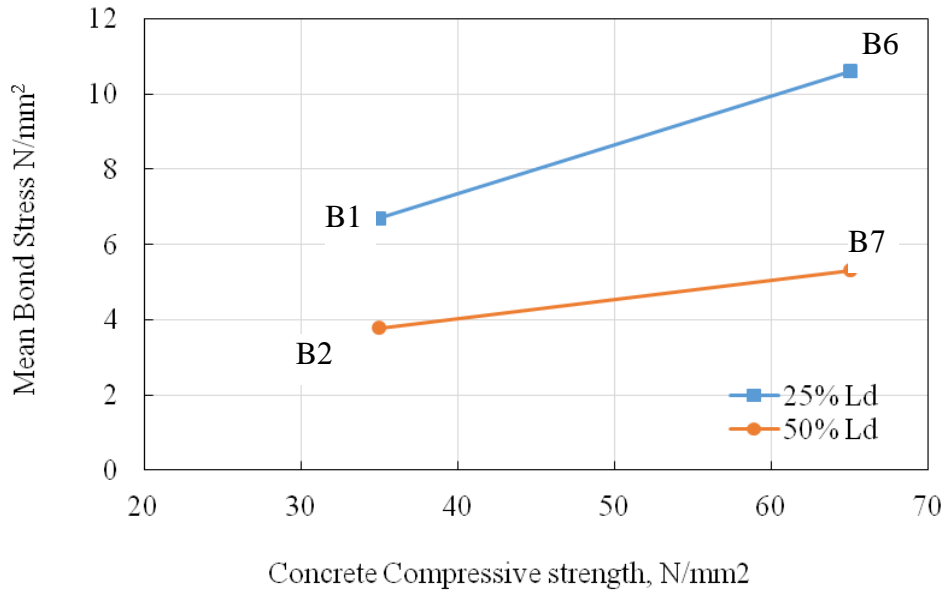

Figure 15 Bond stress for beams B1, B2, B6 and B7

5.3.5 Ultimate steel stress values along the splice length

Figure 16 shows steel stress values along the splice length for Beams B6 and B7. It can be seen from the figure that the maximum steel stress at the left side of the splice length for B6 with 25% L_d and B7 with 50% L_d was the same and equals 595 N/mm² which is slightly higher than the yield stress. This may be attributed to the high strength SCC for these specimens which resulted in a better bond for $L_d = 25\%$ compared with that of normal strength SCC of the other test specimens. In addition, the non-constant moment in the shear zone would affect the stress at the ends of the lap splices and this may vary with the change of the lap length. Again, the reliability

of the results comes from the simulation of the experimental work with what is normally done in the real construction.

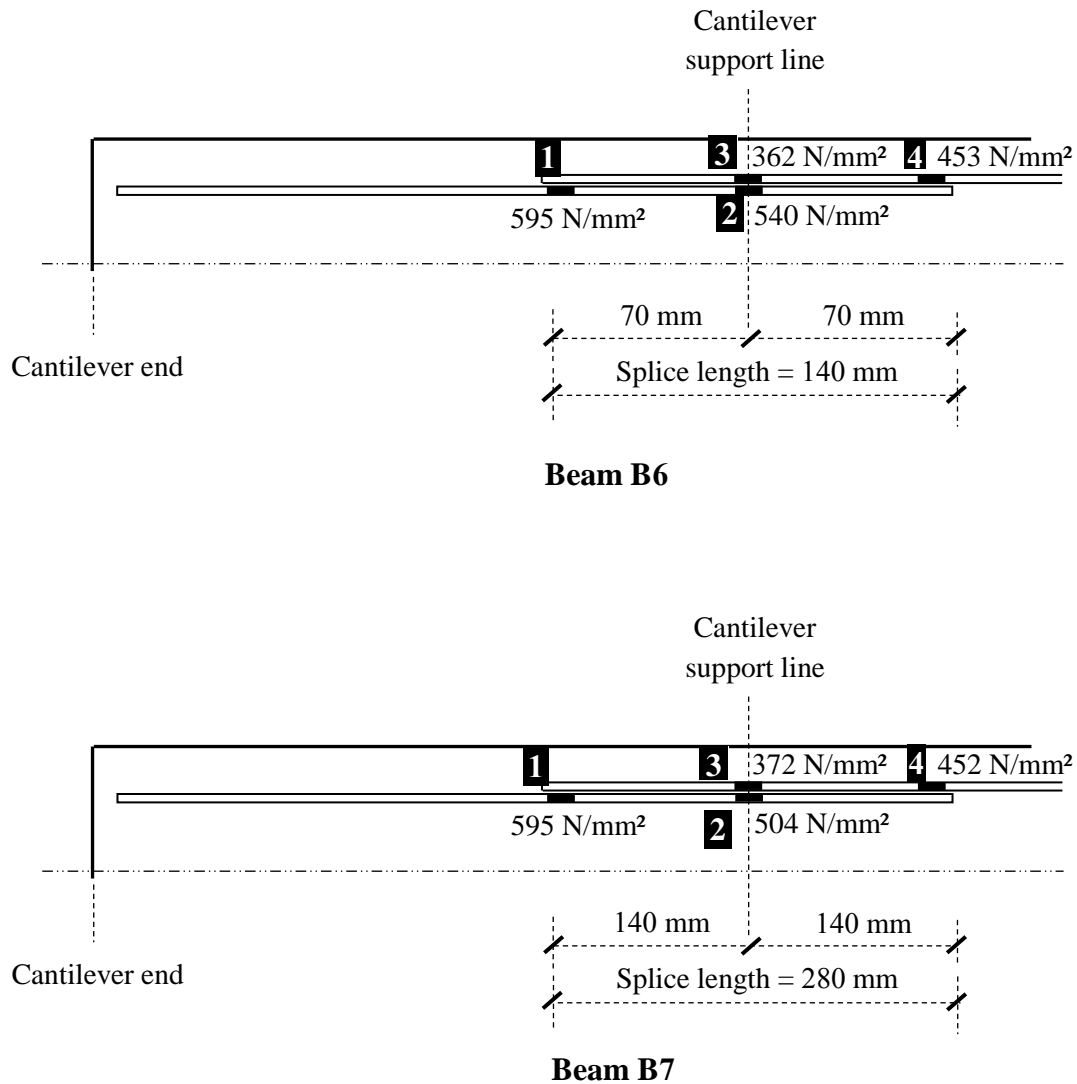

Figure 16 Ultimate steel stress values calculated from steel strains at strain gauges' locations shown in Figure 2 (Shear links omitted for clarity) Not to scale

5.3.6 Load – steel strain curve

The load strain relationships for longitudinal bars at splice locations in specimens B1, B2, B6 and B7 are shown in Figure 17. It can be seen from the figure that the strains did not exceed the yield value for the used steel reinforcement (2887 μ strain) at strain gauge positions 2, 3 and 4. The

recorded steel strains show that steel strain of B6 and B7 ($f_{ck, cube} = 65 \text{ N/mm}^2$) is less than the steel strain of B1 and B2 ($f_{ck, cube} = 35 \text{ N/mm}^2$) at the same load level. This may be attributed to the increase of concrete compressive strength.

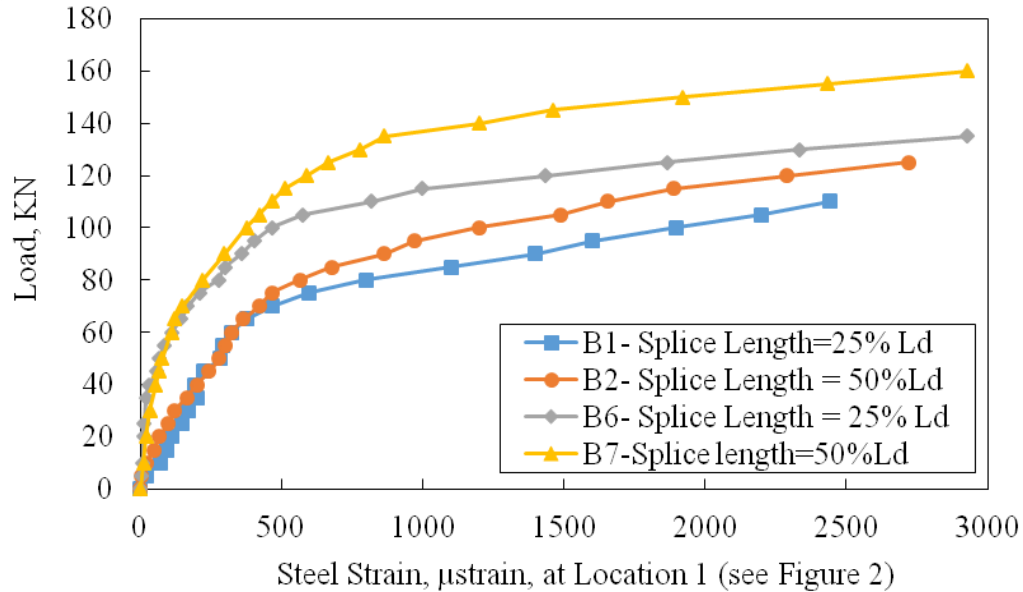

Figure 17 Load-longitudinal steel strain of Beams B1, B2, B6 and B7

5.4 Effect of Concrete Type (NVC versus SCC)

5.4.1 Crack pattern

Crack patterns for Group 3-NVC beams (B8 and B9) are shown in Figure 5. It can be seen from the figure that Beam B8 had the cracks concentrated at the middle of lap splice only, getting wider towards the top and reaching the support. Failure occurred at maximum moment with the formation of vertical cracks in both sides of the beams at the end of splice. Beam B9 had the cracks concentrated at lap splice ends only followed by cracks inside the lap zone and diagonal cracks near the support. Failure occurred at maximum moment by formation of vertical crack in both sides of the beam at the end of splice.

5.4.2 Cracking and Ultimate Load capacity

The first crack appeared at a load of 30 kN for Beam B8, and at 35 kN for Beam B9. Increasing the lap splice length from 25% L_d for B8 to 50% L_d for B9 increased the max capacity by 44% as reported in Table 4. Comparing B1-B2 with B8-B9, it was found that SCC and NVC beams have the same values of first cracking loads, but the ultimate load for SCC beams increased by 38% for splice length 25% L_d (B1 compared with B8) and approximately 9% for splice length 50% L_d (B2 compared with B9). It can be argued that the bond failure often results from the failure of the concrete which fully encapsulate the bar during placing or bleeding and segregation of the NVC before hardening which reduce the contact on the surface while the fluidity and cohesion of SCC minimize these negative effects.

5.4.3 Load - deflection curve and energy absorption

Figure 18 shows load-deflection curves for beams in Group 1 - SCC (B1-B2) and Group 3 - NVC (B8-B9). It can be seen that for Beam B8, the area under the curve was approximately 71% of that of Beam B1. In addition, for Beam B9, the area under the curve was approximately 82% of that of Beam B2. This indicates that the ductility of B8 and B9 is less than those of Beams B1 and B2 due to the lower ultimate loads of B8 and B9. In addition, the figure shows that Beams B1 and B2 exhibited less deflection compared to those of Beams B8 and B9 at the same load level. Figure 19 shows the energy absorption values of Groups 1-SCC Beams (B1 and B2) and 3-NVC (B8 and B9). It can be seen that the energy absorption values of NVC Specimens B8 and B9 were less than those of SCC Beams B1 and B2 by 29% and 18%, respectively. This indicates that SCC enabled the beams to be more ductile and, in turn, resulted in moment capacity improvement for Beams B1 and B2.

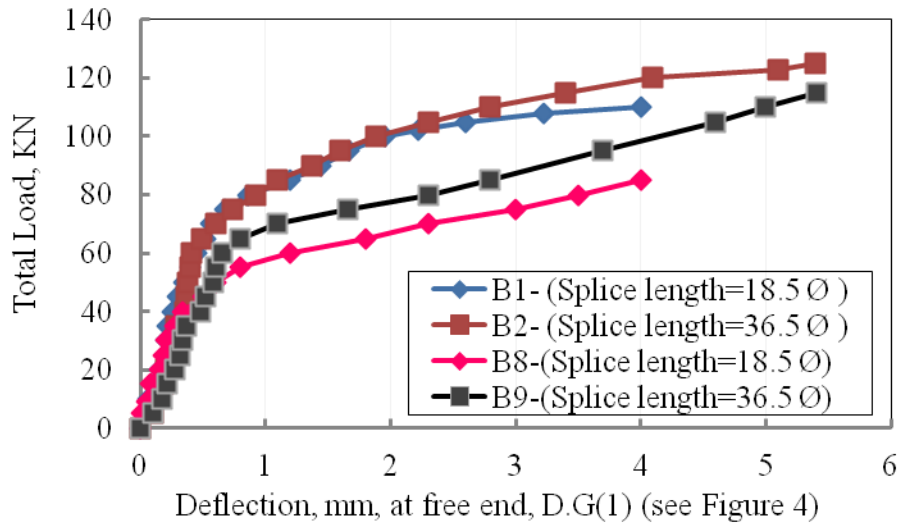

Figure 18 load-deflection curves for B1, B2, B8 and B9

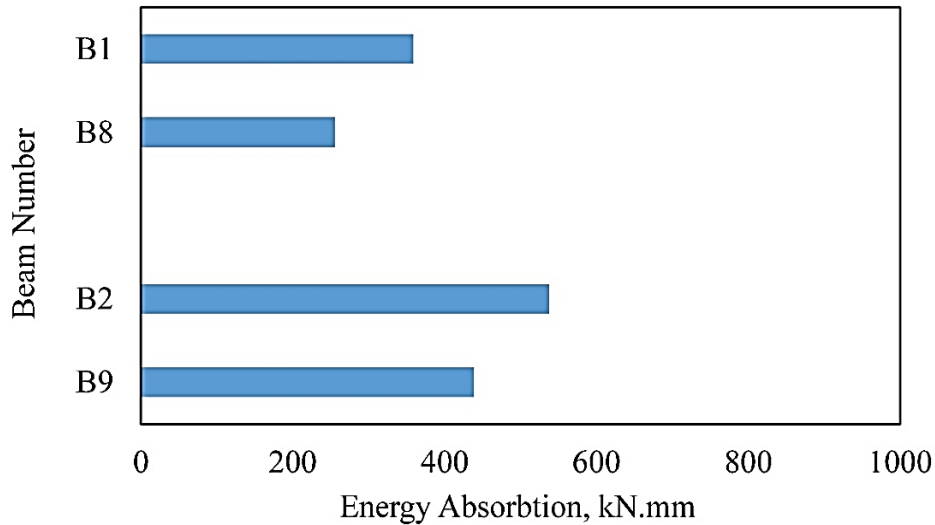

Figure 19 Energy absorption for beams B1, B2, B8, and B9

5.4.4 Bond stress at the splice

The bond stress results for beams B1, B2, B8, and B9 are shown in Figure 20. The mean bond stress of Beams B1 and B2 are higher than those of B8 and B9 by 15% and 11%, respectively.

This indicated that using SCC increased the bond stress in reinforcement bars at splices compared to that of NVC. These findings are generally in agreement with Chan *et al* [4], Pandurangan *et al.* [5] and Turk *et al* [14] but to different degrees.

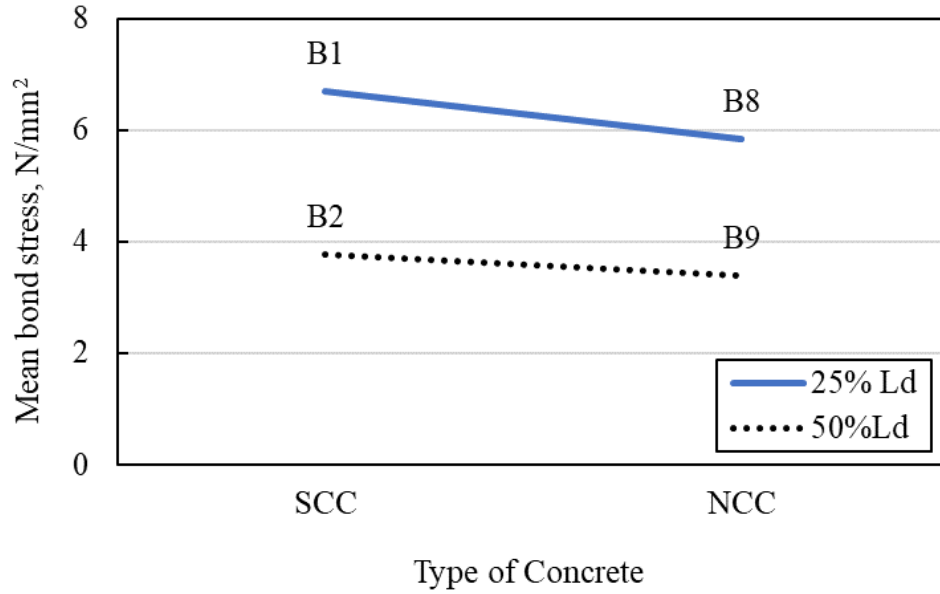

Figure 20 Bond stress along the lap splice of beams B1, B2, B8 and B9

5.4.5 Ultimate steel stress values along the splice length

Figure 21 shows the steel stress values along the splice length for Beams B8 and B9. It can be seen from the figure that the maximum steel stress at the left side of the lap-splice of B9 with 50% L_d splice length was 497 N/mm² which is higher than that of B8 with 25% L_d splice length at the same location by 15 %. It can be argued that the NVC in these studied specimens behave differently from SCC studied beams. It can be noted for the studied beams that the moment in the shear zone is not constant, and this would affect the stress at the ends of the lap splices and vary with the change of the lap length.

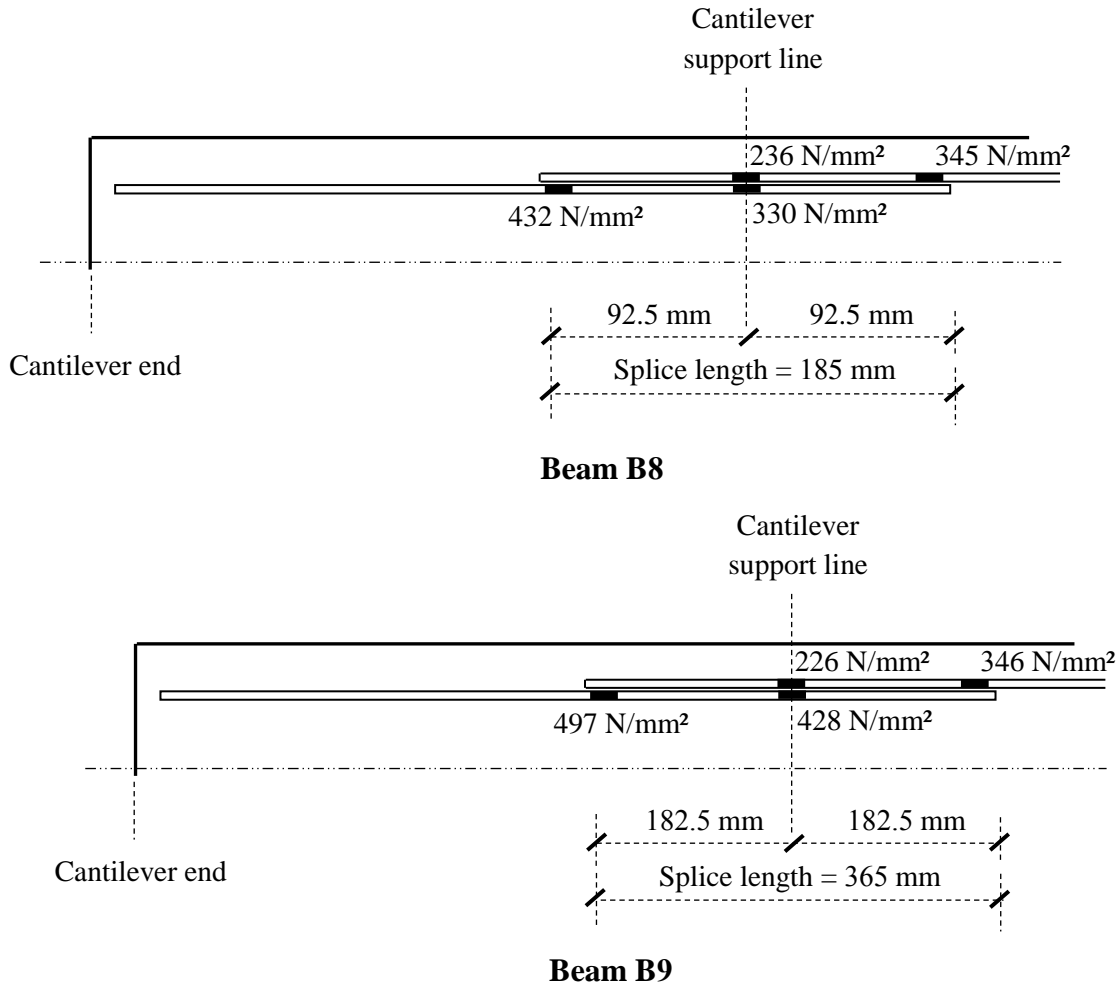

Figure 21 Ultimate steel stress values calculated from steel strains at strain gauges' locations shown in Figure 2 (Shear links omitted for clarity) Not to scale

5.4.6 Load – steel strain curves

The load strain relationships for longitudinal bars at the splice locations in specimens B1, B2, B8, and B9 are shown in Figure 22. It can be seen from the figure that the strains did not exceed the yield strength for the used steel reinforcement (2887 μ strain). The recorded steel strains show that the ultimate steel strain values of Specimens B8 and B9 (NVC) are lower than those of Specimens B1 and B2 (SCC). This may be attributed to the lower ultimate loads of NVC specimens compared to those of SCC counterparts.

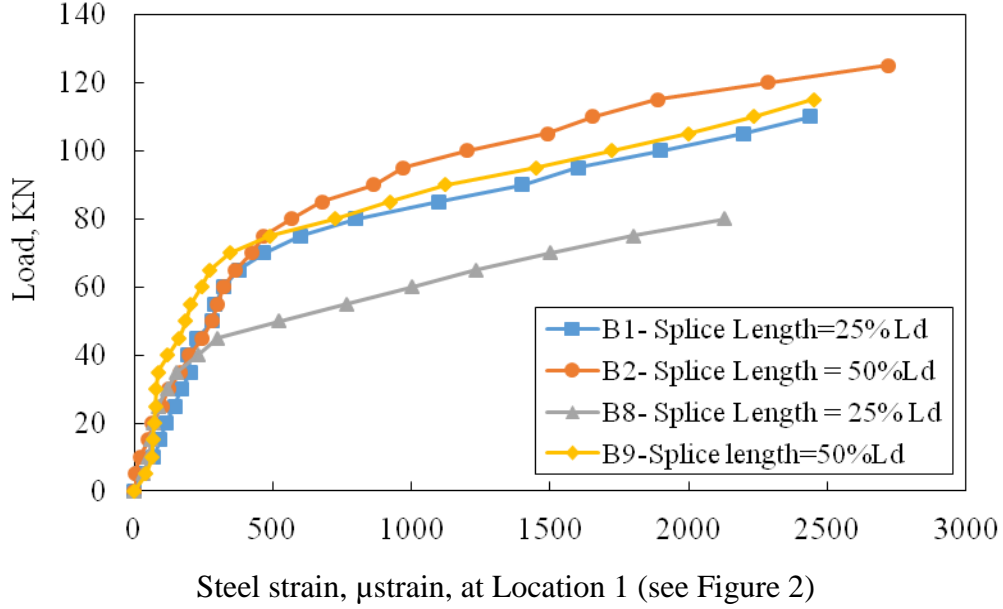

Figure 22 Load-longitudinal steel strain of Beams B1, B2, B8 and B9

6. Prediction of Bond Strength

A number of researchers have developed equations which represent the bond between the reinforcing bars and concrete.

The equation presented by [Orangun et al \[29\]](#) is expressed as follows:

$$U_u = \left[1.22 + 3.23 \frac{c}{d_b} + 53 \frac{d_b}{l_d} \right] \sqrt{f_{ck}} \quad \text{psi} \quad (\text{will be converted to N/mm}^2) \quad (6)$$

The equation presented by [Chapman and Shah \[30\]](#) is expressed as follows:

$$U_u = \left[3.5 + 3.4 \left(\frac{c}{d_b} \right) + 57 \left(\frac{d_b}{l_d} \right) \right] \sqrt{f_{ck}} \quad \text{psi} \quad (\text{will be converted to N/mm}^2) \quad (7)$$

The equations presented by [Aslani and Nejadi \[31\]](#) is expressed as follows:

For deformed rebar and SCC

$$U_u = \left(0.672 \left(\frac{c}{d_b} \right)^{0.6} + 4.8 \left(\frac{d_b}{l_d} \right) \right) (f_{ck})^{0.55} \quad (8)$$

For deformed rebar and NVC

$$U_u = \left(0.679 \left(\frac{c}{d_b} \right)^{0.6} + 3.88 \left(\frac{d_b}{l_d} \right) \right) (f_{ck})^{0.55} \quad (9)$$

The equation presented by Mousavi et al [32] is expressed as follows:

$$U_u = \frac{3.9 \sqrt{f_{ck}}}{1 + 12 e^{-0.54 \left(\frac{c_{min}}{d_b} + 10 \frac{d_b}{l_d} \right)}} \quad (10)$$

The bond stress values in the current study were calculated according to ACI 318 [25], Equations (3-5), by substituting the steel stress at ultimate loads. Steel stress values were calculated from first principles using the measured ultimate load strains at Location 1 (see Figure 2). The calculated bond stress values for the studied beams are reported in Table 4.

The predicted bond stress values using Equations (6-10) are recorded in Table 5 and shown in Figure 23. The bond stress for each specimen was divided by the predicted values to obtain the bond efficiencies listed in Table 5. It can be observed from the table and figure that the predictions obtained by the equations developed by Orangun et al [29]; Chapman and Shah [30]; Aslani and Nejadi [31]; Mousavi et al [32] were in a reasonable agreement with the calculated bond stress values for beams with a splice length equals to 25% L_d . Table 5 shows that the bond efficiencies for Orangun et al [29] predictions were the best among the four predictions.

On the other hand, Table 5 and Figure 23 show that the predictions using Equations (6-10) overestimated the results for specimens with splice length 50% L_d , In addition, it can be observed that there are discrepancies between the measured bond stress and the values predicted by Equations (5- 9). It can be argued that the bond stress measured on rather short anchorage lengths is the reliable one because the true distribution of bond stress is almost uniform and is therefore approximated reasonably well by the average bond stress measured. In addition, these equations were originally developed for short splices only.

Table 5 Experimental and predicted bond stress for Beams B1, B2, B6, B7, B8, and B9

Beam ID	Lap splice length	Mean bond stress, N/mm^2 , u , (Table 4)	Predicted bond stress, u , N/mm^2				Bond efficiency			
			Orangun et al model [29]	Chapman & Shah [30]	Aslani and Nejadi [31]	Mousavi et al [32]	u/p [29]	u/p [30]	u/p [31]	u/p [32]
B1	25% L_d	6.70	5.45	6.76	9.1	6.33	1.23	1.00	0.74	1.06
B6		10.6	7.99	9.82	13.54	9.21	1.33	1.08	0.78	1.15
B8		5.84	5.45	6.76	8.86	6.33	1.07	0.86	0.66	0.92
B2	50% L_d	3.78	4.82	6.08	8.28	5.72	0.78	0.62	0.46	0.66
B7		5.31	6.84	8.58	12	8.05	0.78	0.62	0.44	0.66
B9		3.40	4.82	6.08	8.2	5.72	0.71	0.56	0.41	0.59

* u/p = experimental / predicted bond stress

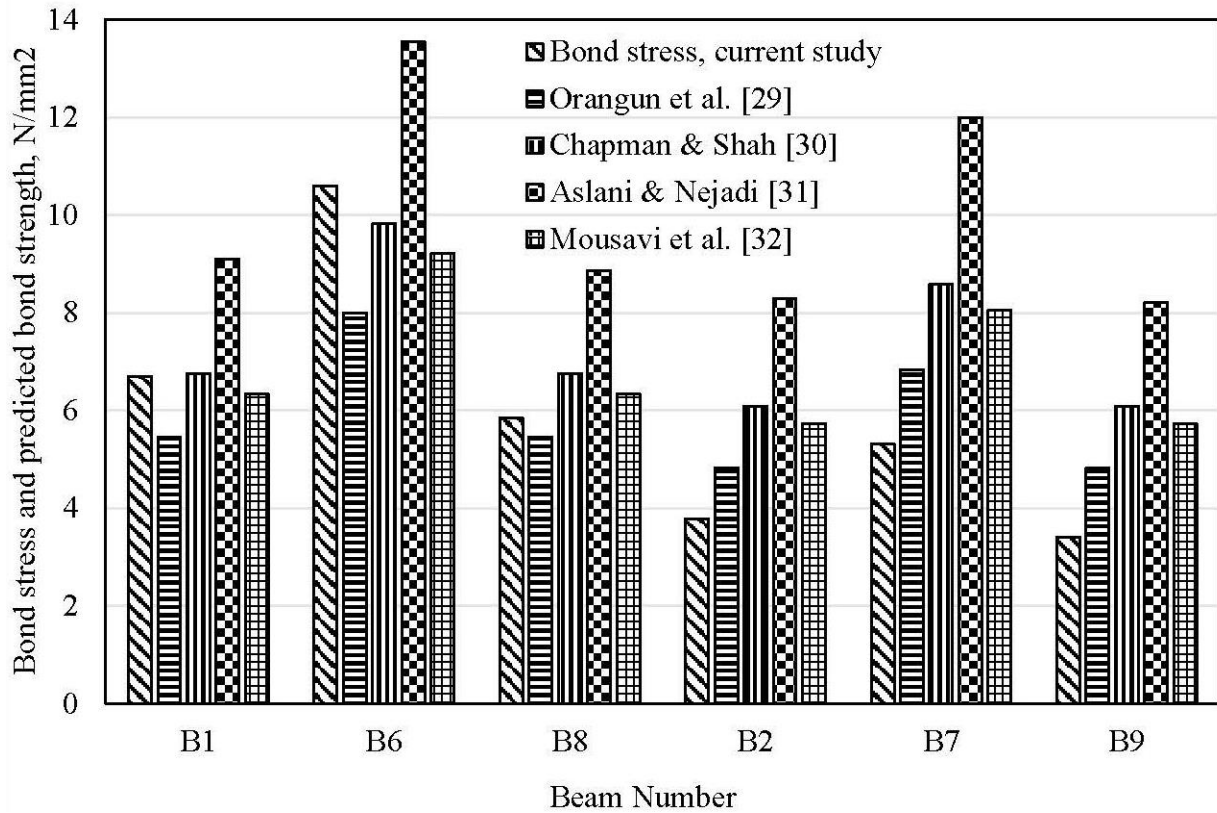

Figure 23 Bond stress results in the current study and those predicted by other researchers

7. Conclusions

This study investigated the effect of splice lap length, compressive strength, type of concrete (SCC or NVC) and concrete cover depth on the bond behaviour between SCC and top steel bars under tensile loading. The empirical equations given in the design codes (Eurocode2 [22], ECP 203-2018 [23]), for calculating splice lengths for SCC beams were considered. The bond behaviour of lap splices in NVC and SCC were compared, and differences were highlighted as follows:

The increase in splice length from 25% L_d to 100% (full) L_d significantly improved the energy absorption and changed the failure mode of the studied beams to a more ductile manner. The energy absorption of the beam with a splice length of 100% L_d were higher than that of the reference beam by 28%.

The reduction of the effective depth from increasing the concrete cover from 30mm to 50mm, while keeping the total concrete section constant, resulted in a reduction in the maximum ultimate load capacity by 40%, a reduction of the first cracking load by 33%, and a reduction in energy absorption and bond stress by approximately 71%, and 14%, respectively.

The increase in concrete compressive strength from 35 N/mm² to 65 N/mm² increased energy absorption and bond stress by approximately 73%, and 58% for splice length, 25% L_d . while the increases were 54%, and 40 % for splice length, 50% L_d .

The ultimate load capacity of the SCC specimens with splice lengths of 25% L_d and 50% L_d were higher than that of the NVC specimens by 38% and 9%, respectively. Although no significant difference in ductility was observed, the energy absorption of the NVC specimens were less than that of the SCC specimens by 29% for splice length 25% L_d and by 18% for splice length 50% L_d .

1
2
3
4 The maximum steel stress in SCC beams in the lap splice zone, was higher than that for NVC
5
6 specimens. The mean bond stress values, for SCC beams with 25% and 50% lap splice lengths,
7
8 were higher than those of NVC beams, with the same lap splice lengths, by 15% and 11%,
9
10 respectively. The ultimate steel strain of SCC specimens is higher than that of NVC ones.
11
12
13

14 The empirical equations from the literature were used to predict the bond stress for the studied
15
16 beams. The prediction was in good agreement with the experimental results for short splice length
17
18 equals 25% L_d while it overestimated the results for specimens with longer splices. This agrees
19
20 with the state of the art as these equations were developed originally for short anchorage lengths.
21
22
23

24 **Declarations**

25 **Availability of data and materials**

26
27 All data generated or analysed during this study are included in this published article
28
29
30
31

32 **Competing interests**

33
34 The authors declare that they have no competing interests
35
36
37

38 **Funding**

39
40 Not applicable
41
42

43 **Authors' contributions**

44
45 Wael Montaser: Supervised the student, participated in writing and reviewing it.
46
47

48 Ibrahim G. Shaaban: Wrote the article, shared in the theoretical work and shared in the final
49
50 revision.
51

52 Joseph P. Rizzuto: Revised the first draft, shared in the theoretical work and shared in the final
53
54 revision
55

56 Amr H. Zaher: Prepared the research plan and shared in the original revision of the paper
57

58 Ahmed Rashad (deceased): Shared in the research plan and supervised the experimental work
59

60 Shorouk Mohamed El Sadany: Carried out the experimental work.
61
62
63
64
65

1
2
3
4 **Acknowledgements**

5
6
7 Not applicable
8
9

10 **Author Information**

11
12 **Wael Montaser**

13
14 BSc, MSc, PhD

15
16 Associate Professor

17
18
19 Head of Construction and Building Department
20
21

22 **Ibrahim G. Shaaban**

23
24 BSc, MSc, PhD, MICE, CEng, MStructE, FICE, FStructE, SFHEA

25
26 Reader of Civil Engineering
27
28

29 **Joseph P. Rizzuto**

30
31 BSc, MSc, PhD, CertEd, CEng, MICE, MStructE, MCIHT

32
33 Professor of Civil Engineering
34
35

36 **Amr H. Zaher**

37
38 BSc, MSc, PhD

39
40 Professor of Concrete Structures
41
42

43 **Ahmed Rashad (deceased)**

44
45 BSc, MSc, PhD

46
47 Associate professor
48
49

50
51 **Shorouk Mohamed El Sadany**

52
53 BSc, MSc

54
55 Assistant Lecturer
56
57
58
59
60
61
62
63
64
65

References

- [1] Furuya N, Itohiya T, Arima I. 1994. Development and application of highly flowing concrete for mass concrete anchorages of Akashi Kaikyo Bridge. Proc of Int Conf on high performance concrete (supplementary papers), Singapore. Detroit, USA: American Concrete Institute; p. 371–96.
- [2] Schiessl, A. and Zilch, K., 2001, October. The effect of the modified composition of SCC on shear and bond behavior. In *Proceedings of the 2nd International Symposium on Self-Compacting Concrete, Tokyo, Japan* (Vol. 2325, p. 501506).
- [3] Domone, P.L., 2007. A review of the hardened mechanical properties of self-compacting concrete. *Cement and concrete composites*, 29 (1), pp.1-12.
- [4] Chan, Y.W., Chen, Y.S. and Liu, Y.S., 2003. Development of bond strength of reinforcement steel in self-consolidating concrete. *Structural Journal*, 100(4), pp.490-498.
- [5] Pandurangan, K, Kothandaraman, S., and Sreedaran, D., (2010) “A study on the bond strength of tension lap splices in self compacting concrete”, *Materials and Structures*, Vol. 43, pp. 1113–1121, [DOI 10.1617/s11527-009-9570-3](https://doi.org/10.1617/s11527-009-9570-3)
- [6] Castel, A., Vidal, T., Viriyametanont, K. and François, R., 2006. Effect of reinforcing bar orientation and location on bond with self-consolidating concrete. *ACI Materials Journal*, 103(4), p.559.
- [7] Cattaneo, S. and Rosati, G., 2009. Bond between steel and self-consolidating concrete: experiments and modeling. *ACI Structural Journal*, 106(4), p.540.
- [8] Miguel C. S. Nepomuceno, and Luís F. A. Bernardo, 2019 “Evaluation of Self-Compacting Concrete Strength with Non-Destructive Tests for Concrete Structures”, *Applied Science*, 9, 5109; [doi:10.3390/app9235109](https://doi.org/10.3390/app9235109), www.mdpi.com/journal/applsci

1
2
3
4 [9] Esfahani MR, Lachemi M, Kianoush MR. 2008. Top-bar effect of steel bars in self-
5 consolidating concrete (SCC). *Cem Concr Compos*;30(1):52–60.
6
7

8
9 [10] Ponmalar, S., 2018. Bond behavior of self-compacting concrete. *Selected Scientific Papers-
10 Journal of Civil Engineering*, 13(s1), pp.95-105.
11
12

13
14 [11] Khan, S. U., and Ayub, T., May 2021, “Mechanical Properties of Hybrid Self- Compacting
15 Fibre- Reinforced Concrete (SCC- FRC) Containing PVA and PP Fibres”, *Iranian Journal of
16 Science and Technology, Transactions of Civil Engineering*, [https://doi.org/10.1007/s40996-021-
17 00652-5](https://doi.org/10.1007/s40996-021-00652-5)
18
19
20
21
22

23
24 [12] Self-Compacting Concrete European Project Group, 2005. *The European guidelines for self-
25 compacting concrete: Specification, production and use*. International Bureau for Precast
26 Concrete (BIBM).
27
28
29

30
31 [13] Kaihua Liu, Chaoying Zou, Jiachuan Yan & Xianbin Shan (2020): Bond behavior of
32 deformed steel bars in self-compacting concrete, *Journal of Adhesion Science and Technology*,
33
34
35
36
37
38
39
40
41
42
43
44
45
46
47
48
49
50
51
52
53
54
55
56
57
58
59
60
61
62
63
64
65

66 [14] Turk, K., Benli,A., and Calayir, Y., 2008, “Bond strength of tension lap-splices in full scale
67 self-compacting concrete beams”, *Turkish Journal of Engineering and Environmental Science*,
68
69
70
71
72
73
74
75
76
77
78
79
80
81
82
83
84
85
86
87
88
89
90
91
92
93
94
95
96
97
98
99
100
101
102
103
104
105
106
107
108
109
110
111
112
113
114
115
116
117
118
119
120
121
122
123
124
125
126
127
128
129
130
131
132
133
134
135
136
137
138
139
140
141
142
143
144
145
146
147
148
149
150
151
152
153
154
155
156
157
158
159
160
161
162
163
164
165
166
167
168
169
170
171
172
173
174
175
176
177
178
179
180
181
182
183
184
185
186
187
188
189
190
191
192
193
194
195
196
197
198
199
200
201
202
203
204
205
206
207
208
209
210
211
212
213
214
215
216
217
218
219
220
221
222
223
224
225
226
227
228
229
230
231
232
233
234
235
236
237
238
239
240
241
242
243
244
245
246
247
248
249
250
251
252
253
254
255
256
257
258
259
260
261
262
263
264
265
266
267
268
269
270
271
272
273
274
275
276
277
278
279
280
281
282
283
284
285
286
287
288
289
290
291
292
293
294
295
296
297
298
299
300
301
302
303
304
305
306
307
308
309
310
311
312
313
314
315
316
317
318
319
320
321
322
323
324
325
326
327
328
329
330
331
332
333
334
335
336
337
338
339
340
341
342
343
344
345
346
347
348
349
350
351
352
353
354
355
356
357
358
359
360
361
362
363
364
365
366
367
368
369
370
371
372
373
374
375
376
377
378
379
380
381
382
383
384
385
386
387
388
389
390
391
392
393
394
395
396
397
398
399
400
401
402
403
404
405
406
407
408
409
410
411
412
413
414
415
416
417
418
419
420
421
422
423
424
425
426
427
428
429
430
431
432
433
434
435
436
437
438
439
440
441
442
443
444
445
446
447
448
449
450
451
452
453
454
455
456
457
458
459
460
461
462
463
464
465
466
467
468
469
470
471
472
473
474
475
476
477
478
479
480
481
482
483
484
485
486
487
488
489
490
491
492
493
494
495
496
497
498
499
500
501
502
503
504
505
506
507
508
509
510
511
512
513
514
515
516
517
518
519
520
521
522
523
524
525
526
527
528
529
530
531
532
533
534
535
536
537
538
539
540
541
542
543
544
545
546
547
548
549
550
551
552
553
554
555
556
557
558
559
560
561
562
563
564
565
566
567
568
569
570
571
572
573
574
575
576
577
578
579
580
581
582
583
584
585
586
587
588
589
590
591
592
593
594
595
596
597
598
599
600
601
602
603
604
605
606
607
608
609
610
611
612
613
614
615
616
617
618
619
620
621
622
623
624
625
626
627
628
629
630
631
632
633
634
635
636
637
638
639
640
641
642
643
644
645
646
647
648
649
650
651
652
653
654
655
656
657
658
659
660
661
662
663
664
665
666
667
668
669
670
671
672
673
674
675
676
677
678
679
680
681
682
683
684
685
686
687
688
689
690
691
692
693
694
695
696
697
698
699
700
701
702
703
704
705
706
707
708
709
710
711
712
713
714
715
716
717
718
719
720
721
722
723
724
725
726
727
728
729
730
731
732
733
734
735
736
737
738
739
740
741
742
743
744
745
746
747
748
749
750
751
752
753
754
755
756
757
758
759
760
761
762
763
764
765
766
767
768
769
770
771
772
773
774
775
776
777
778
779
780
781
782
783
784
785
786
787
788
789
790
791
792
793
794
795
796
797
798
799
800
801
802
803
804
805
806
807
808
809
810
811
812
813
814
815
816
817
818
819
820
821
822
823
824
825
826
827
828
829
830
831
832
833
834
835
836
837
838
839
840
841
842
843
844
845
846
847
848
849
850
851
852
853
854
855
856
857
858
859
860
861
862
863
864
865
866
867
868
869
870
871
872
873
874
875
876
877
878
879
880
881
882
883
884
885
886
887
888
889
890
891
892
893
894
895
896
897
898
899
900
901
902
903
904
905
906
907
908
909
910
911
912
913
914
915
916
917
918
919
920
921
922
923
924
925
926
927
928
929
930
931
932
933
934
935
936
937
938
939
940
941
942
943
944
945
946
947
948
949
950
951
952
953
954
955
956
957
958
959
960
961
962
963
964
965
966
967
968
969
970
971
972
973
974
975
976
977
978
979
980
981
982
983
984
985
986
987
988
989
990
991
992
993
994
995
996
997
998
999
1000

99 [15] El-Azab, M.A., Mohamed, H.M. and Farahat, A., 2014. Effect of tension lap splice on the
100 behavior of high strength self-compacted concrete beams. *Alexandria Engineering Journal*, 53(2),
101 pp.319-328.
102
103

104 [16] Wu C.H., Chen M.Y, and Chen H.J., November 2018, “Bond Behavior of Tension Bar at
105 Lap Splice of SCC Beam”, *Key Engineering Materials*, Vol. 789, pp. 126-130, DOI:
106
107
108
109
110
111
112
113
114
115
116
117
118
119
120
121
122
123
124
125
126
127
128
129
130
131
132
133
134
135
136
137
138
139
140
141
142
143
144
145
146
147
148
149
150
151
152
153
154
155
156
157
158
159
160
161
162
163
164
165
166
167
168
169
170
171
172
173
174
175
176
177
178
179
180
181
182
183
184
185
186
187
188
189
190
191
192
193
194
195
196
197
198
199
200
201
202
203
204
205
206
207
208
209
210
211
212
213
214
215
216
217
218
219
220
221
222
223
224
225
226
227
228
229
230
231
232
233
234
235
236
237
238
239
240
241
242
243
244
245
246
247
248
249
250
251
252
253
254
255
256
257
258
259
260
261
262
263
264
265
266
267
268
269
270
271
272
273
274
275
276
277
278
279
280
281
282
283
284
285
286
287
288
289
290
291
292
293
294
295
296
297
298
299
300
301
302
303
304
305
306
307
308
309
310
311
312
313
314
315
316
317
318
319
320
321
322
323
324
325
326
327
328
329
330
331
332
333
334
335
336
337
338
339
340
341
342
343
344
345
346
347
348
349
350
351
352
353
354
355
356
357
358
359
360
361
362
363
364
365
366
367
368
369
370
371
372
373
374
375
376
377
378
379
380
381
382
383
384
385
386
387
388
389
390
391
392
393
394
395
396
397
398
399
400
401
402
403
404
405
406
407
408
409
410
411
412
413
414
415
416
417
418
419
420
421
422
423
424
425
426
427
428
429
430
431
432
433
434
435
436
437
438
439
440
441
442
443
444
445
446
447
448
449
450
451
452
453
454
455
456
457
458
459
460
461
462
463
464
465
466
467
468
469
470
471
472
473
474
475
476
477
478
479
480
481
482
483
484
485
486
487
488
489
490
491
492
493
494
495
496
497
498
499
500
501
502
503
504
505
506
507
508
509
510
511
512
513
514
515
516
517
518
519
520
521
522
523
524
525
526
527
528
529
530
531
532
533
534
535
536
537
538
539
540
541
542
543
544
545
546
547
548
549
550
551
552
553
554
555
556
557
558
559
560
561
562
563
564
565
566
567
568
569
570
571
572
573
574
575
576
577
578
579
580
581
582
583
584
585
586
587
588
589
590
591
592
593
594
595
596
597
598
599
600
601
602
603
604
605
606
607
608
609
610
611
612
613
614
615
616
617
618
619
620
621
622
623
624
625
626
627
628
629
630
631
632
633
634
635
636
637
638
639
640
641
642
643
644
645
646
647
648
649
650
651
652
653
654
655
656
657
658
659
660
661
662
663
664
665
666
667
668
669
670
671
672
673
674
675
676
677
678
679
680
681
682
683
684
685
686
687
688
689
690
691
692
693
694
695
696
697
698
699
700
701
702
703
704
705
706
707
708
709
710
711
712
713
714
715
716
717
718
719
720
721
722
723
724
725
726
727
728
729
730
731
732
733
734
735
736
737
738
739
740
741
742
743
744
745
746
747
748
749
750
751
752
753
754
755
756
757
758
759
760
761
762
763
764
765
766
767
768
769
770
771
772
773
774
775
776
777
778
779
780
781
782
783
784
785
786
787
788
789
790
791
792
793
794
795
796
797
798
799
800
801
802
803
804
805
806
807
808
809
810
811
812
813
814
815
816
817
818
819
820
821
822
823
824
825
826
827
828
829
830
831
832
833
834
835
836
837
838
839
840
841
842
843
844
845
846
847
848
849
850
851
852
853
854
855
856
857
858
859
860
861
862
863
864
865
866
867
868
869
870
871
872
873
874
875
876
877
878
879
880
881
882
883
884
885
886
887
888
889
890
891
892
893
894
895
896
897
898
899
900
901
902
903
904
905
906
907
908
909
910
911
912
913
914
915
916
917
918
919
920
921
922
923
924
925
926
927
928
929
930
931
932
933
934
935
936
937
938
939
940
941
942
943
944
945
946
947
948
949
950
951
952
953
954
955
956
957
958
959
960
961
962
963
964
965
966
967
968
969
970
971
972
973
974
975
976
977
978
979
980
981
982
983
984
985
986
987
988
989
990
991
992
993
994
995
996
997
998
999
1000

1
2
3
4 [10.4028/www.scientific.net/KEM.789.126](https://doi.org/10.4028/www.scientific.net/KEM.789.126)
5
6

7 [17] Almeida Filho, F.M., Barragán, B.E., Casas, J.R. and El Debs, A.L.H., 2008. Variability of
8 the bond and mechanical properties of self-compacting concrete. *Revista IBRACON de Estruturas*
9 *e Materiais*, 1(1), pp.31-57.
10
11

12 [18] Zuo, J., and Darwin, D., 2000, “Splice Strength of Conventional and High Relative Rib Area
13 Bars in Normal and High-Strength Concrete,” *ACI Structural Journal*, V. 97, No. 4, July-Aug.,
14 pp. 630-641.
15
16

17 [19] Zhao, D., Zhou, Y., Xing, F., Sui, L., Ye, Z., Fu, H. Bond behavior and failure mechanism of
18 fiber-reinforced polymer bar–engineered cementitious composite interface. *Engineering*
19 *structures*, (2021) 243, art. no. 112520. <https://doi.org/10.1016/j.engstruct.2021.112520>
20
21

22 [20] D. Zhao, J. Pan, Y. Zhou, L. Sui, Z. Ye. New types of steel-FRP composite bar with round
23 steel bar inner core: mechanical properties and bonding performances in concrete. *Constr. Build.*
24 *Mater.*, 242 (2020), Article 118062. <https://doi.org/10.1016/j.conbuildmat.2020.118062>
25
26

27 [21] El Sadany, S. M., Rashad, A., and Montaser, W., 2020, “Bond Behavior of Upper
28 Reinforcing Steel Bars in Self-Compacting Concrete Beams at Shear Zone”, *International Journal*
29 *of Engineering Research & Technology (IJERT)*, Vol. 9 Issue 05, pp. 449-458, ISSN: 2278-0181,
30 <http://www.ijert.org>
31
32

33 [22] EN 1992-1-1:2015 Eurocode 2 – Design of concrete structures – Part 1-1: General rules and
34 rules for buildings.
35
36

37 [23] Egyptian Code of Design and Construction of Reinforced Concrete Structures, ECP
38 203-2018.
39
40
41
42
43
44
45
46
47
48
49
50
51
52
53
54
55
56
57
58
59
60
61
62
63
64
65

1
2
3
4 [24] BS EN 206: 2013, Concrete – Specification, performance, production and conformity,
5
6 British Standards Institution, London, 2013.

7
8
9 [25] American Concrete Institute, ACI 318-19 Metric Building Code Requirements for
10
11 Structural Concrete and Commentary, American Concrete Institute, Farmington Hills,
12
13 Mich., USA, 2019.

14
15
16 [26] ACI (American Concrete Institute). (2003). “Bond and development of straight reinforcing
17
18 bars in tension.” ACI 408R–03, Farmington Hills, MI.

19
20
21 [27] Bournas, D. A., and Triantafyllou, T. C. (2011). “Bond strength of lap spliced bars in
22
23 concrete confined with composite jackets.” *J. Compo Constr.*, 10.1061/(ASCE)CC.1943-
24
25 5614.0000078, 156–167.

26
27
28 [28] E. Canbay and R. J. Frosch, “Bond strength of lap-spliced bars,” *ACI Struct. J.*, vol. 102, no.
29
30 4, pp. 605–614, 2005.

31
32
33 [29] Orangun, C.O., Jirsa, J.O. and Breen, J.E., 1977, March. A reevaluation of test data on
34
35 development length and splices. In *Journal Proceedings* (Vol. 74, No. 3, pp. 114-122).

36
37
38 [30] Chapman, R. A., & Shah, S. P. (1987). EARLY-AGED BOND STRENGTH IN
39
40 REINFORCED CONCRETE. *ACI Materials Journal*, 84(6), 501-510.

41
42
43 [31] Aslani F, Nejadi S. Bond behavior of reinforcement in conventional and self-compacting
44
45 concrete. *Adv Struct Eng.* 2012;15(12):2033–2051.

46
47
48 [32] Mousavi SS, Dehestani M, Mousavi KK. Bond strength and development length of steel bar
49
50 in unconfined self-consolidating concrete. *Eng Struct.* 2017; 131:587–598.

51
52
53 [33] Mosley, W. H., Hulse, R., and Bungey, J. H., “Reinforced Concrete Design To Eurocode 2
54
55 (EC2)”, DOI, <https://doi.org/10.1007/978-1-349-13413-7>, Palgrave, London, eBook ISBN978-1-
56
57 349-13413-7.



Click here to access/download
Supplementary Material
Reviewer-comments-and-Reply-2.docx

