



UWL REPOSITORY

repository.uwl.ac.uk

Content-aware packet scheduling strategy for medical ultrasound videos over
LTE wireless networks

Nasralla, Moustafa M., Razaak, Manzoor, Rehman, Ikram ORCID logo ORCID:
<https://orcid.org/0000-0003-0115-9024> and Martini, Maria G. (2018) Content-aware packet
scheduling strategy for medical ultrasound videos over LTE wireless networks. *Computer
Networks*, 140. pp. 126-137. ISSN 1389-1286

<http://dx.doi.org/10.1016/j.comnet.2018.05.014>

This is the Accepted Version of the final output.

UWL repository link: <https://repository.uwl.ac.uk/id/eprint/6232/>

Alternative formats: If you require this document in an alternative format, please contact:
open.research@uwl.ac.uk

Copyright: Creative Commons: Attribution-Noncommercial-No Derivative Works 4.0

Copyright and moral rights for the publications made accessible in the public portal are retained by the authors and/or other copyright owners and it is a condition of accessing publications that users recognise and abide by the legal requirements associated with these rights.

Take down policy: If you believe that this document breaches copyright, please contact us at open.research@uwl.ac.uk providing details, and we will remove access to the work immediately and investigate your claim.

Rights Retention Statement:

Content-Aware Packet Scheduling Strategy for Medical Ultrasound Videos over LTE Wireless Networks

Moustafa M. Nasralla^{a,*}, Manzoor Razaak^b, Ikram U. Rehman^b, Maria G. Martini^b

^a*Department of Communications and Networks Engineering, Prince Sultan University, Riyadh, Saudi Arabia*

^b*Department of Science, Engineering and Computing, Kingston University London, UK*

Abstract

In parallel to the advancements in communication technologies, telemedicine research has continually adapted to develop various healthcare applications. One of the latest wireless technologies that is Long-Term Evolution (LTE) is being increasingly deployed across developed countries and rapidly adopted by developing countries. In this paper, a content-aware packet scheduling approach for medical ultrasound videos is proposed. This work introduces a utility function based on the temporal complexity of the video frames. The utility function is used with four schedulers to prioritise the video packets based on their temporal complexity and type of frame (e.g., I frame). The results show that the utility function improves the packet delay performance obtained in our simulations when compared with content-unaware approaches. Further, gain in average PSNR and SSIM is also observed in the received video quality. Research on content-aware packet scheduling for telemedicine applications over advanced wireless networks is limited and our work contributes towards addressing this research gap.

Keywords: Packet Scheduling Algorithms, Resource Allocation, Content

*Corresponding author

Email address: mnasralla@psu.edu.sa (Moustafa M. Nasralla)

URL: <http://www.psu.edu.sa/en/Colleges/Engineering> (Moustafa M. Nasralla)

1. Introduction

4th generation wireless technologies such as the Third Generation Partnership Project (3GPP) LTE/LTE-Advanced (LTE-A) and the enhanced capabilities of the recent smart-phones and tablets have fostered the growth of multimedia and interactive bandwidth demanding services, such as medical video streaming, video-on-demand, interactive gaming, and 2D and 3D video streaming over wireless networks. The high data rates and other performance benefits provided by LTE enable transmission of high resolution medical images and videos. However, despite superior performance with respect to previous wireless technologies, LTE systems still carry the risk of transmission impairments due to factors such as high data traffic, bandwidth and other network constraints. Therefore, it is important, especially for telemedicine systems, to ensure efficient transmission of medical images and video with minimal transmission impairments via application oriented design of LTE systems.

An LTE system for a given application must provide high Quality of Service (QoS) and Quality of Experience (QoE). QoS is a network centric performance assessment approach that may consider various network performance parameters such as packet loss rate, average system throughput, end-to-end packet delay, system spectral efficiency and system fairness [1]. The QoS requirements may depend on the type of application. For instance, for a real time application such as live video streaming, the end-to-end packet delay requirement would be highly strict. On the other hand, QoE is a user centric evaluation approach which reflects the user's experience and satisfaction for the service used. Video quality evaluation for video services is usually performed using two methods: objective and subjective evaluations. The former is conducted using mathematical based metrics (e.g. Mean Square Error (MSE) [2], Peak Signal to Noise Ratio (PSNR) [2], and Structural Similarity (SSIM) [3]), whereas the latter is based on the

Human Vision System (HVS) as is dependent on the human observation [4]. A study on subjective and objective video quality assessment, defining all the metrics mentioned earlier, is available for instance in [5] and a good and thorough review is provided in [6].

This paper has three main contributions. A summary of the contributions to knowledge is listed below:

1. Including the content-awareness for evaluating medical QoE. The proposed utility function-based scheduling algorithm incorporates important factors related to ultrasound video streaming application such as the network conditions and the video content type, in order to obtain a holistic measurement of the video quality received. The importance of content-awareness can be contemplated for example in an emergency situation, where the medical videos are transmitted from an ambulance to the hospital under bandwidth limited conditions. The medical experts at the hospital will be receiving the guaranteed important information (e.g. Region of Interest (RoI)) with best quality delivered over such constrained channel due to the existence of content-aware scheduling algorithms.
2. Introducing a utility function based on the temporal complexity of the video frames. The utility function is used with four schedulers to prioritise the video packets based on their temporal complexity and type of frames (e.g. I frame). The proposed utility function helps in creating a prioritising strategy during the transmission of ultrasound videos that gives priority to the more important frames (in terms of temporal complexity and frame type), enabling to achieve better performance in QoS and QoE measures. The proposed utility function forms the basis to modify the existing downlink packet scheduling algorithms, making them content-aware packet schedulers in an LTE wireless system. This results in enhanced transmission performance of LTE systems for medical ultrasound videos.
3. Improving the existing schedulers by including the proposed utility func-

tion to maximise the video quality, where the scheduler at the Medium
Access Control (MAC) layer is responsible for optimally sharing the ra-
dio resources among video flows with diverse video contents and bit-rate
60 requirements.

To the best of our knowledge, the aforementioned points are novel and are our
major contributions in the field of telemedicine.

The paper is organised as follows. Section 2 presents different classes of content-
aware and content-unaware packet scheduling strategies. A proposed utility
65 function for content-aware packet scheduling strategies is introduced in Section
3. The simulation set-up and comparative performance analysis are presented
in Section 4 and Section 5, respectively. Concluding remarks are discussed in
Section 6.

2. Background & Related Work

70 2.1. Content-Aware Packet Scheduling

In a packet based transmission system such as LTE, the videos to be transmitted
are encoded in packets at the server side. Packet scheduling, in general, is a
strategy to allocate network resources for transmission of packets with a target
of minimal image/video distortion and maximum fair resource utilisation by the
75 network to service multiple clients requesting data from the server.

Several strategies for packet scheduling have been developed and can be broadly
classified into: *Content-unaware* and *Content-aware* packet scheduling strate-
gies. Content-unaware strategies are conventional methods mainly focusing on
considering QoS constraint requirements such as packet delay constraints for
80 packet scheduling. Content-aware strategies consider video contents and its fea-
tures to design scheduling approach with a goal to attain maximum video quality
at the client side. Figure 1 illustrates a content-aware scheduling approach.

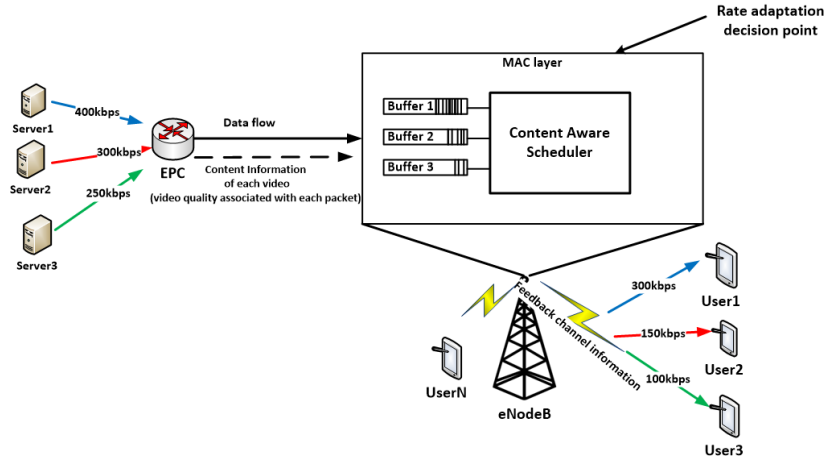

Figure 1: Content-aware scheduling approach.

The content information is obtained from the video and is used in decision-making process of the packet scheduler. Typically, the impact that the content of a particular packet may have on the received video quality is used as a means to assign packet priority and is used to provide a priority-based resource allocation to the packets. The content information chosen to make the priority decision depends on the application type and the choice of the network designer.

In packet scheduling, a *Utility Function* is applied to assist the scheduler in making priority-based scheduling decisions. In content-aware packet scheduling approaches, the *Utility Function* is dependent on the video content. The utility function is typically a function of the video quality, which defines the effect a particular packet may have on the final video quality and is usually derived from the contents of the video. A frequent approach to define a content-aware utility function is to measure the distortion a packet may induce to the received video if the packet is lost during transmission. Various approaches to define the utility function for packet scheduling have been presented in the literature, some of which are reviewed in the following section.

2.2. Related Work

100 Content-aware packet scheduling has been a subject of research interest and various approaches have been proposed in the literature. In [7] additive distortion as a utility function for scheduling was proposed. The utility function defines the amount of distortion a particular packet may introduce into the video quality based on the number of packets dependent on that packet for decoding. In 105 congestion scenarios, the packet which is expected to give least distortion is dropped. Pahalawatta *et al.* defined a utility function to schedule the packets based on their relative contribution to the overall quality of the video and apply the utility function to a gradient scheduler whose gradient reflects the contribution of the packet to the perceived video quality [8].

110 Considering I and P-frame packets from the application layer and scheduling packets at the MAC layer based on their importance and channel status information from the PHY layer is an approach proposed in [9]. Here, I frame packets are considered to be more important than P packets since they have a higher impact on error propagation in a Group of Pictures (GOP) and hence 115 receive higher priority. In [10], a content-aware packet scheduling for High Efficiency Video Coding (HEVC) encoded video transmission over LTE networks was presented. The contents of the video are prioritised based on the importance of the slices of the compressed video and based on its actual contributions to the motion compensation. Similarly, various approaches for content-aware 120 packet scheduling approaches have been presented in the literature such as in [11, 12, 13, 14, 15, 16, 17, 18].

In the context of telemedicine, very little work has been done on topics of packet scheduling for medical images and videos. For instance, in [19], an adaptive bandwidth reservation scheme and fair scheduling scheme for telemedicine 125 transmission is presented. The proposed scheduling approach gives importance to the packets based on the type of traffic they are transmitting, i.e. ECG, X-ray, image or video. The results showed that their system model was able

to achieve efficient transmission with the strict QoS requirements they had set. Video distribution techniques considering the suitability of WiMAX networks
130 in terms of resource allocation and scheduling were explored for telemedicine applications in [20]. However, there was no content-aware packet scheduling approach proposed.

In a nutshell, the concept of content-awareness for packet scheduling in the field of telemedicine is still in its infancy. In practice, it is important to utilise
135 different medical video sequences in order to efficiently and fairly prioritise them. The earlier studies mostly considered a single medical video sequence instead of multiple sequences for transmission. Secondly, in literature, medical video streaming-based downlink packet scheduling algorithms are mostly based on QoS parameters and are content-blind. Content-blind scheduling approaches
140 have shown to produce similar results for different content types under similar encoder and wireless network settings. Such scheduling approaches are assumed to fit all content types. However, in reality, these do not produce accurate results as video contents contain different temporal features, which are their unique signatures. Therefore, classification of video-content type is essential, in
145 order to group medical video sequences based on their temporal complexities (e.g. slow movement and fast movement) [21, 22].

Furthermore, in literature, content-aware packet scheduling has mostly considered regular videos that are used in daily applications such as video streaming, television, etc. However, there are limited studies that have applied packet
150 scheduling for medical videos, which is a research gap. Moreover, medical videos are distinct from regular videos and are significantly characterised by video features such as edges, grayscale pixels, and motions. Usually medical videos have a specific RoI that carry higher diagnostic value to clinicians. Thus, exploring these important features specific to medical videos can lead to enhanced
155 content-aware packet scheduling. Our work demonstrates that the existing packet scheduling methods can be adapted to suit telemedicine applications. We proposed and implemented a utility function that allowed us to adapt the

packet schedulers to function by considering the characteristics of the ultrasound videos of the test datasets, i.e. motion characteristic. The study presented is
160 an example on how by considering key features of different medical videos, an improved performance on packet scheduling in wireless systems can be achieved.

3. Proposed Utility Function

The contribution of this work is to propose a utility function for medical ultrasound videos based on the temporal complexity (TC) of the frames in the
165 video. From telemedicine perspective, there is no such medical video quality assessment database that evaluates QoE, considering the network conditions and temporal features of the video content combined together in a single framework.

The temporal complexity (TC) is a measure of the activity levels between two successive frames. A high TC measure implies a significant change in activity
170 levels between the two frames typically due to high change in motion activities or a scene change. Conversely, a low TC measure indicates low or insignificant changes between two successive frames and hence possibility of having higher redundant data between the frames. It is worth mentioning that the temporal features are regarded as content signatures for the respective video sequences.
175 They are different for each video sequence as long as the content of the video is distinctive. In general terms, they are a measure of content similarity in a specific video sequence in a multi-dimensional hyperspace.

It has been studied that frames with higher temporal complexity are sensitive to packet loss and jitter as they carry more information [23]. This emphasises
180 the importance of the temporal complexity and its impact on the QoS. For instance, a low-movement video sequence gives better QoS results, followed by medium-movement and then high-movement. This is because with higher temporal complexities, the loss of information could be higher, leading to a greater impact on the QoS and QoE [24].

185 Temporal complexities have also been used for video quality assessment in works
such as [25], [26]. The studies have shown that temporal complexities of frames
can be used as relative weights to parameters of video perceptual quality models.
Further, studies on HVS have shown that human eye is sensitive to temporal
variations for a frequency up to approximately 80 Hz [27]. For instance, tests
190 conducted by Derrington *et al.* in [28] found that cellular units in human eye
are sensitive to temporal stimuli. Furthermore, humans tend to overlook minor
impairments in low temporal videos more than in video sequences with high
temporal variations [24].

Moreover, it is important to note that the temporal estimation involves com-
195 putational complexities; therefore, a good practice is to select the key frames
that contain the most scene changes rather than extracting temporal features
from the entire video sequence. This technique contributes towards reducing
the computational complexities.

In the context of ultrasound videos, since scene change is not an occurring
200 phenomenon, a high TC measure indicates higher motion activities between
two successive frames. Hence, the influence of motion on HVS perception is
essential, as discussed and proved in [29] and [30]. Considering the significance
of motion perception, we make an assumption that frames with high TC, which
in turn reflects high motion activities, would induce high distortion and can have
205 higher impact on the received video quality if that particular frame is lost or is
impaired during transmission. Therefore, we propose a utility function which
gives high priority to packets belonging to a frame with high TC measure. The
utility function enables sorting the packets of a video in transmission buffer for
each user based on the contribution of each packet may have on the overall
210 received video quality. Details of computing TC and utility function is provided
below.

The TC measures change in successive frames across a given video. High motion
in adjacent frames results in higher values of TC and hence is relevant for our

assumption that the loss of high TC valued frames introduces high distortions. The ITU-T Recommendation P.910 document describes a method to compute TC and is measured based on the motion difference between frames [31]. For a Sobel filtered frame F of a video, $M_n(i, j)$ represents the difference between the pixel values for the same location in space in successive frames and is defined as:

$$M_n(i, j) = F_n(i, j) - F_{n-1}(i, j). \quad (1)$$

$F_n(i, j)$ is the pixel value at the i^{th} row and j^{th} column of n^{th} frame in time.

The TC value, TC_{F_n} , for a frame F_n can be represented by the $M_n(i, j)$ value computed using (1) and the TC value for the video is obtained using (2) and is computed as the maximum over time of the standard deviation over space of $M_n(i, j)$ over all i and j for all $n = 1, 2, \dots, k$ frames, shown as:

$$TC_{F_{max}} = \max_{time}(std_{space}[M_n(i, j)]). \quad (2)$$

The TC_{F_n} values are then mapped to a range interval $[0.1, 1]$ resulting in the frame with maximum TC value, $TC_{F_{max}}$, getting a value of 1 and 0.1 for the frame with least TC value. This mapping function is defined in (3).

$$g(TC_{F_n}) = 0.9 * (TC_{F_n} - TC_{F_{min}}) / (TC_{F_{max}} - TC_{F_{min}}) + 0.1. \quad (3)$$

Now, using (3), the importance or *utility* U_F of frame F can be given as a function of its TC.

$$U_F = g(TC_F); \quad 0.1 \leq U_F \leq 1. \quad (4)$$

We consider the “IPPP...” configuration of MPEG video frame encoding widely used for delay constraint transmission of video data as it gives low delay performance. In this configuration, the I frame uses intra-frame coding and is the most important frame since it has a high bitrate and also the first P frame following 215 it is dependent on I frame for decoding. The subsequent P frames following the

first P frame are dependent on the previous P frame for the prediction data required for its decoding. Therefore, I frames are highly important since the loss
 220 or corruption of an I frame during transmission could have a severe negative impact on video quality, as the decoding of subsequent P frames until the next I frame gets affected. Thus, we assign a value of 1, i.e. maximum priority, for the I frames in the video.

At a given transmission time slot, t , for a user, i , there are $P_{r,s}$ packets in the transmission buffer for $s = 1, 2, 3 \dots p$ packets belonging to $r = 1, 2, 3, \dots f$ frames. The utility of each packet s belonging to frame r can then be calculated as

$$U_{P_{r,s}} = \begin{cases} 1, & I \text{ frame} \\ U_F, & P \text{ or } B \text{ Frame.} \end{cases} \quad (5)$$

In simple words, Equation (5) allocates a higher value to a packet belonging to
 225 a frame with high TC value, that gets priority for resource allocation for transmission under congested network conditions. This strategy would reduce the probability of dropping a packet belonging to a frame, which could potentially have higher impact on the received video quality.

Furthermore, the medical videos can be prioritised w.r.t the regular videos by
 230 simply assigning them a higher QoS Class Identifier (QCI) value at the QoS bearer, enabling the proposed utility function to distinguish between the medical and regular video traffic and hence will give priority to the former. According to [32, 33, 34, 35, 36], medical video streaming application demands augmented requirements for robust and clinically acceptable diagnosis when compared to
 235 regular video applications. Also, the QoS and QoE requirements (in terms of bounds and performance metrics) are higher due to the fact that medical data is critical and sensitive in nature.

4. Simulation Setup

To test the performance of the proposed utility function, a simulation study is
240 carried out. The utility function is used in the existing packet scheduling algo-
rithms, whose performance is evaluated for video transmission over a simulated
LTE network through a simulator called LTE-Sim [37] (more details about the
simulation environment are provided in Subsection 4.3). The used simulation
setup mimics real world experiments and is widely accepted testing methodol-
245 ogy in the wireless research community [37]. This allows us to model different
scenarios and it is designed to behave and provide similar performance that
a real world wireless network would provide. Further, the simulator facilitates
easy capturing of the statistics such as packet losses and delays, which otherwise
is difficult to capture in real world experiments. Details of our simulation setup
250 are provided below.

4.1. Video Sequences

The study included four medical ultrasound video sequences, two cardiac and
two liver videos. Each video sequence consisted of 100 frames with a frame
resolution of 640×416 . To generate encoded video packets, the videos were
255 encoded with the latest video compression standard, HEVC. The videos were
encoded at frame rate of 25 frames per second. To encode the videos into
packets, the *SliceMode* was activated during the encoding and 500 bytes were
allocated for each slice. The frequency of I frames was set every 25 frames
including the first frame. Therefore, we had four I frames at frame 1, 25, 50,
260 and 75. The bitrate of the encoded videos was set at 250 kbps. The encoder
chose adaptive Quantisation Parameter (QP) in order to achieve the target
bitrate of 250 kbps. An example frame from each of the four video sequences
considered in our simulations is illustrated in Figure 2.

Prior to encoding, the TC of each frame of each video is calculated using Equa-
265 tion (1). The TC of each video is illustrated in Figure 3. It can be observed

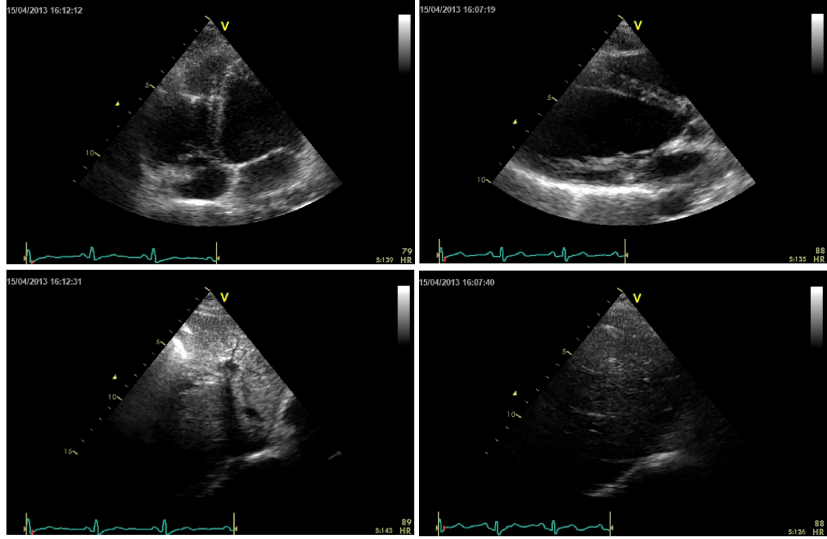

Figure 2: Example frames of videos considered in our tests. Clockwise from top-left: Echocardiography in 4 chambers view. The right ventricle is dilated; Echocardiography: parasternal long axis view, displaying left atrium and ventricle, aorta and mitral valves; Echocardiography: subcostal view displays the liver, the inferior vena cava and hepatic veins; Echocardiography in subcostal view: the liver and hepatic veins are visualised.

that the liver sequences have lower TCs when compared to cardiac sequences. This is because cardiac sequences consist of rapid repetitive motions reflecting the dilation and contraction of the heart muscles. The liver sequences are characterised by lower motion relative to cardiac sequences. Hence, our test
 270 video dataset includes sequences with both low and high TCs to allow better performance evaluation.

4.2. Scheduling Strategies

The proposed utility function is applied on four different scheduling strategies for its performance evaluation. Each scheduling algorithm has a different way
 275 of calculating the metric required to allocate the network resources to the users. The proposed content-aware scheduling algorithm is not only aware of the delay and utility function of the packets, but also of the QCI and the channel state information through average transmission data-rate $\bar{R}_i(t)$ of each flow associated

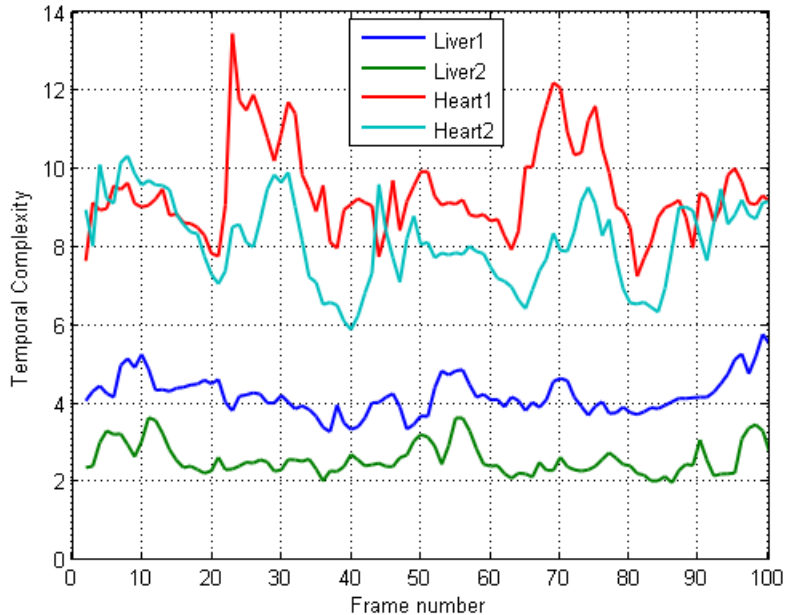

Figure 3: Temporal Complexity of the video sequences considered.

to the i -th user as well as instantaneous available data-rate $r_{i,j}(t)$ for each sub-
 280 channel. The average and instantaneous data-rates provide information about
 the available bandwidth and guarantee fairness among competing users for the
 resources. In the case of bandwidth unavailability, the proposed scheduler is
 designed to switch from non-Guaranteed Bit Rate (non-GBR) to Guaranteed
 Bit Rate (GBR) type of QCI. GBR bearer is a dedicated bearer usually assigned
 285 to VoIP application, and has been assigned in the telemedicine domain, to
 guarantee bandwidth allocation for urgent mobile telemedicine traffic [38]. For
 critical telemedicine traffic, this type of bearer will always guarantee bandwidth.
 Hence, the provision of seamless switching between the non-GBR to GBR bearer
 in the LTE standard has been the motivation of this paper to include QCI-
 290 awareness in the proposed scheduler, so that the critical and clinically sensitive
 medical data does not get compromised.

In the following, we present four scheduling approaches whose performance was

evaluated in our simulation studies using the proposed content-aware utility function. For each scheduler, the proposed utility function is used as a parameter
 295 to give weights to the packet based on its importance with respect to the TC and is highlighted with the term U_P in the equations of each scheduler described below. For the benchmark test where the transmission test does not use the proposed content-aware utility function, the value of the function is set to 1.

- *Proportional fair scheduler*: The proportional fair (PF) scheduler assigns the Physical Resource Block (PRB)s by taking into account both the channel quality and the past user average throughput [39]. This scheduler is very suitable to support non-Real Time (NRT) traffics. The goal of this scheduler is to improve the total network throughput and to guarantee fairness among the flows. The metric $W_{i,j}(t)$ in this scheduler is defined as the ratio between the instantaneous data rate of the i -th flow in the j -th sub-channel (i.e., $r_{i,j}(t)$) and the average data rate of the i -th flow (i.e., $\bar{R}_i(t)$). The following equation illustrates the metric used to represent the Proportional Fair (PF) scheduler along with the proposed utility function:

$$W_{i,j}(t) = \frac{r_{i,j}(t)}{\bar{R}_i(t)} * U_P \quad (6)$$

where $r_{i,j}(t)$ is computed based on the Adaptive Modulation and Cod-
 300 ing (AMC) module, which is selected according to the Channel Quality Indicator (CQI) feedback received from the User Equipment (UE). This feedback represents the channel quality (e.g., Signal to Interference Noise Ratio (SINR)) of the j -th sub-channel associated to the the i -th flow. $\bar{R}_i(t)$ is the estimated average data rate.

- *M-LWDF Scheduler*: The Modified Largest Weighted Delay First (M-LWDF) scheduler is developed to support multiple Real Time (RT) data users [40]. The scheduler assigns PRBs to different flows by considering the properties of the classical PF rule and the Head of Line (HoL) packet delay for the RT flows. The following equation illustrates the metric used to represent

the M-LWDF scheduler:

$$W_{i,j}(t) = \begin{cases} \alpha_i(t) * D_{HoL,i}(t) * U_P * (\frac{r_{i,j}(t)}{R_i(t)}), & \text{if } i \in \text{RT} \\ \frac{r_{i,j}(t)}{R_i(t)} * U_P, & \text{if } i \in \text{NRT} \end{cases} \quad (7)$$

305 where U_P denotes the proposed utility function, and $\alpha_i(t)$ is the maximum probability that the HoL packet delay $D_{HoL,i}(t)$ (i.e. delay of the first packet to be transmitted in the queue) exceeds the target delay. Therefore, packets belonging to a RT service will be discarded if they violate the target delay while waiting at the MAC buffer.

- *The EXP/PF scheduler* exponentially increases the priority of RT flows *w.r.t* NRT ones when their HoL packet delays are approaching the target delay. For RT flows, the PF rule is used in conjunction with delay-sensitive parameters to formulate the exponential scheduling rule (EXP/PF). The exponential term will give more importance to the delay parameters than the channel conditions of the flows, which results in supporting the RT flows more. However, for NRT flows the PF rule is solely used to perform packet scheduling among NRT users. The following equation illustrates the metric used to represent the EXP/PF scheduler:

$$W_{i,j}(t) = \begin{cases} \exp\left(U_P * \frac{\alpha_i D_{HoL,i}(t) - h(t)}{1 + \sqrt{h(t)}}\right) \frac{r_{i,j}(t)}{R_i(t)}, & \text{if } i \in \text{RT} \\ \frac{r_{i,j}(t)}{R_i(t)} * U_P, & \text{if } i \in \text{NRT} \end{cases} \quad (8)$$

where $h(t)$ is given by:

$$h(t) = \frac{1}{N_i} \sum_{i=1}^{N_i} \alpha_i D_{HoL,i}(t), \text{ for } i \in \text{RT} \quad (9)$$

310 where most of the definitions of the parameters in Equation 8 are the same as in Equation 7. $h(t)$ refers to the average head-of-line delay (system head-of-line delay), and N_i is the number of active downlink RT flows.

The main goal of this approach is to bound the delays of all the RT flows.

- *Extended M-LWDF Scheduler*: In our simulation, we also considered the scheduler proposed in [41] which is a modification of the M-LWDF and Virtual Token Modified Largest Weighted Delay First (VT-M-LWDF) schedulers. The proposed scheduler adopts the consideration of the queue size and the packets delay parameters in the VT-M-LWDF and M-LWDF rules respectively, in order to improve the performance of the proposed scheduler when serving both RT and NRT classes compared to the benchmark schedulers. This scheduler aims at improving the performance metrics for video services and at the same time maintains a satisfactory level of the performance metrics for other services in the network simultaneously. The following equation illustrates the metric used to represent this scheduler:

$$W_{i,j}(t) = \alpha_i(t)D_{HoL,i}(t)Q_i(t)U_p\left(\frac{r_{i,j}(t)}{\bar{R}_i(t)}\right), \text{ for } i \in \text{RT/NRT} \quad (10)$$

The selection of the aforementioned schedulers depend on the type of application requested. For example, for non-real-time traffics (e.g. P2P, and FTP) PF
 315 is chosen, in which the queues/flows are not bounded with limitations in the scheduling metric, such as target delay or queue size. In contrast, for real-time traffics (e.g. VoIP and live video streaming) M-LWDF is preferred. It is built upon classical PF rule and the HoL packet delay parameter. Further, the
 320 EXP/PF scheduler is adopted when there is a need to prioritise real-time traffic *w.r.t* the non-real-time ones. It is important to note that both M-LWDF and EXP-PF schedulers are downgraded to the classical PF rule when the requested traffic is non-real-time. Lastly, the Extended M-LWDF supports both real-time and non-real-time traffic classes as it provides balanced QoS for multi-traffic
 325 classes simultaneously.

Highlighting the importance of downlink packet scheduling algorithms for balancing QoS in both real-time and non-real-time scenarios, the authors in [41]

proposed QoS balancing scheduling algorithm for multiple traffic classes. The authors reported that the overall performance of the system is balanced and improved remarkably for both real-time and non-real-time applications. However, their study did not consider the combined consequential effects of network conditions and video content types. Omitting the video content characteristics is not desirable, which can affect the QoE levels of a particular content type. Furthermore, the studies with regard to video quality assessment reveal that video content parameters are likely to influence the evaluation of QoS and QoE, and different content types under the interaction of similar encoder parameters and network conditions may result in varying QoS and QoE levels. According to the authors in [22] and [42], video content type is the second most influential factor in evaluating QoE, after QoS, for both real-time and non-real-time traffic classes. Hence, the aforementioned studies provide motivation for designing QoS balancing algorithm for content-based multiple traffic classes. Our proposed algorithms serve to balance QoS parameters in a content-aware framework for both real-time and non-real time traffic classes.

4.3. Simulation Environment

We consider a single LTE cell, in which the users are uniformly distributed. In the centre of the cell, the Evolved NodeB (eNodeB) is positioned, whereas the users are modelled according to a random mobility model. The users mobility is pedestrian with constant speed of 3 km/h. The proposed scenario is simulated using the LTE-Sim simulator [37]. This simulator provides the possibility to design various packet scheduling strategies at the eNodeB MAC layer depending upon the requirements needed.

Simulation results of the relevant performance metrics are averaged over 10 simulation repetitions in order to obtain accurate and reliable results. The simulation parameters used for transmission are reported in Table 1.

Table 1: Simulation parameters for LTE downlink system.

PARAMETERS	VALUE
Bandwidth	3 MHz
Number of PRBs	15
Frame structure	FDD
Cell radius	1 km
E-UTRAN frequency band	1 (2.1 GHz)
Max delay	100 ms
Video bit-rate	250 kbps
Flow duration	4 sec
Simulation time	10 sec
UE speed	3 km/h
Path loss/channel model	Typical Urban (Pedestrian-A propagation model)
Simulation repetitions per scheduler	10

355 4.4. Performance Metrics

The following performance metrics are averaged over simulation repetitions and observed for the different scheduling strategies and scenarios: *Average packet delay*, *average packet loss ratio*, *PSNR*, and *SSIM*. The average packet loss ratio, and the average packet delay are QoS-oriented metrics, whereas the PSNR and
360 SSIM are video quality-oriented metrics.

- The *average packet delay* parameter is calculated by dividing the sum of the received packets delays with the number of received packets.
- The *average packet loss ratio* is calculated by dividing the difference between the transmitted and received packets with the number of transmitted
365 packets.
- The *PSNR* metric is calculated by measuring the signal to noise ratio wherein signal is the original video and noise is the mean square error between the original and distorted video.
- The *SSIM* metric is calculated by measuring the structural similarity be-

370 tween the reference and impaired images by means of luminance, contrast
and structural feature comparison.

5. Results and Discussion

5.1. Results

The performance of the proposed content-aware scheduling approach is analysed
375 via both QoS and QoE parameters. The QoS and QoE are analysed using the
metrics discussed earlier in subsection 4.4. The performance of each scheduler
with and without the use of the utility function is analysed. The packet delay
performance and packet loss ratio metrics for each scheduler is provided in
Figures 4, and 5, respectively. The results are obtained by taking the average
380 performance for all videos for all the simulations carried out in our study. The
spectral efficiency, average throughput, and fairness index are not provided as
they are not affected by the utility function and was found to be same for
simulations with and without the utility function.

In terms of packet delay, the delay parameter in the proposed scheduling algo-
385 rithm is set to change at every Transmission Time Interval (TTI) (i.e., 1 ms).
Besides, each packet has a timestamp, which is associated to packets with high
temporal variations. The delay of the packets with high utility function value
is monitored through their HoL packet delay. Hence, the HoL packet delay
ensures that such packets approaching the delay bound of 100 ms gets a high
390 priority, which will avoid these packets from being dropped. Video contents
are susceptible to delay from the time of capturing to pre-processing, compres-
sion, transmission, and post-processing, each of these stages can introduce a
significant amount of delay, which can deteriorate the QoS and QoE.

Figure 4 presents the packet delay performance of simulations with and without
395 the proposed content-aware utility function. It can be observed that when the

utility function is applied there is an improvement in the network latency or reduction in packet delay for all schedulers considered in our tests. For instance, Exp-PF scheduler shows relatively higher performance than other schedulers. The extended M-LWDF scheduler shows slight improvements only after number of users exceeds 24 users. Other two schedulers, PF and M-LWDF, also show reduction in packet delay especially when the number of users exceeds 16 users. It is important to note that for smaller number of users, the available resources are sufficient enough to be shared. In low congestion, packets do not reside longer in the queues, which in turn enable schedulers to better utilise the resources and assign them for the important contents. Increasing the number of users increases the bandwidth congestion, which affects the delay performance and that is where the improvement in the pattern can be seen between content-aware and content-unaware scheduling algorithms. Therefore, the proposed utility function enables to improve the network latency performance of the schedulers, especially for cases with a high number of users. Furthermore, the improvement in network delay performance is achieved by prioritising the video packets, which have high utility function value and high HoL delay. As mentioned earlier in Section 3, the temporal features of a video content can affect QoS Key Performance Indicators (KPIs), which include the network delay as well. The video packets containing complex temporal variations require longer time to process and are likely to reach their HoL delay if the network resources corresponding to the specific content type are not appropriately assigned. Our proposed scheduling algorithm is content-aware, that is, it processes the extracted video features from the application layer into the MAC layer in the form of utility function. This entire chain of process ensures the network resources best match the video content type requested.

It is important to measure the average PLR, since packet losses have direct impact on video quality. Figure 5 shows the average PLR obtained in our simulation studies. The PLR is obtained by averaging the the packet losses for all the simulations done for 4, 8, 12, 16, 20, 24, and 28 number of users. It can

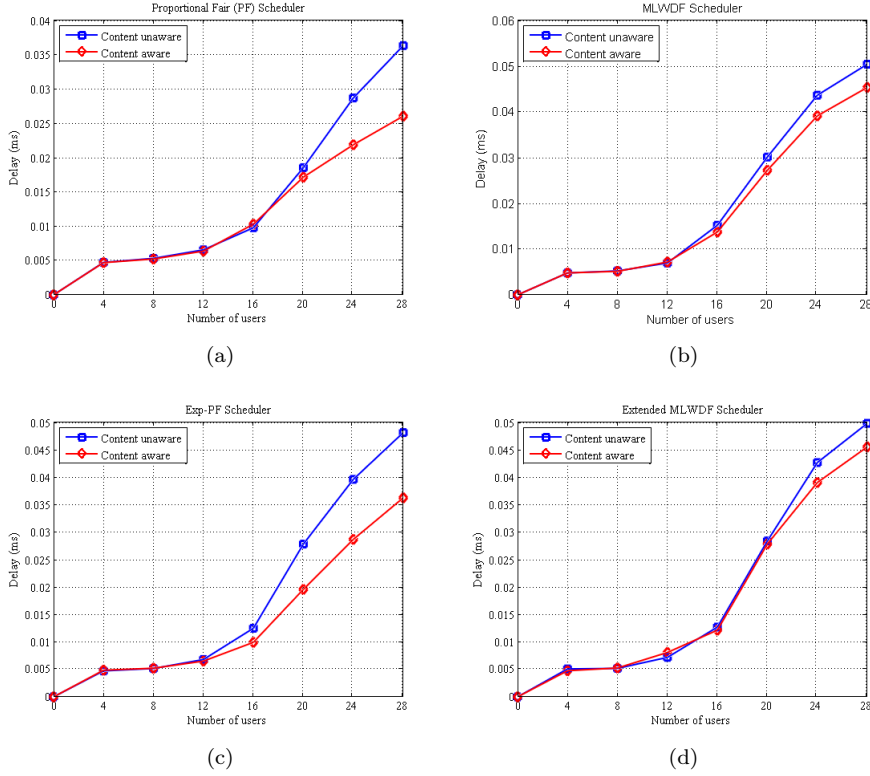

Figure 4: Delay performance for the four scheduling algorithms.

be seen that the PLR is not affected by implementing the utility function. A slight increase in PLR for EXP-PF can be observed after the number of users exceeds 20, however, the change in PLR is in second decimal places which has imperceptible effect on the video quality. Therefore, the PLR performance is not affected by applying the utility function to the schedulers, however, a gain in packet delay performance can be achieved.

To assess the QoE achieved, the received video quality with and without the use of the proposed modification to the utility function, i.e. content-aware utility function, is analysed. The quality is assessed in terms of the PSNR and SSIM achieved. The PLR of the videos for the simulation carried out for each scheduler for two scenarios, with and without the proposed content-aware utility function,

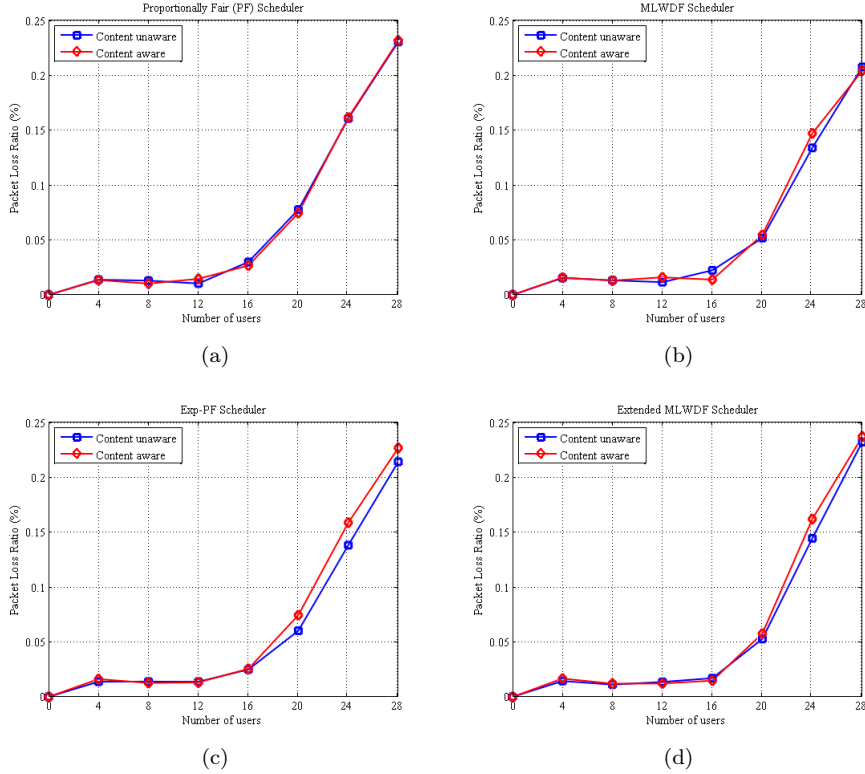

Figure 5: PLR performance for the four scheduling algorithms.

were obtained for up to 20 users. The scenarios exceeding 20 users were not considered as the PLR is usually very high after 20 users and is expected to provide very low quality. The PLR of each video was applied on the encoded video file to generate errors and then decoded to obtain the impaired video. The original video and the impaired video generated were used to compute the PSNR and SSIM. Finally, the average of the PSNR and SSIM of videos received by 20 users were taken. Figure 6 and Figure 7 present the average PSNR and SSIM scores obtained using the four schedulers with and without the proposed content-aware utility function for all the four videos served to 20 different users. It can be seen that for PF, M-LWDF, and Extended M-LWDF schedulers, applying the proposed content-aware utility function results in obtaining better average PSNR and SSIM values. However, for Exp-PF scheduler, the average PSNR

and SSIM values have remained almost the same in our simulation.

450 It is important to note that the average PSNR and SSIM values reported in
Figure 6 and Figure 7 depict the worst case scenario, when the network is
highly congested in the presence of 20 users. In the case of both M-LWDF
and Extended M-LWDF schedulers the obtained average PSNR in the presence
of 20 users is approximately 30 dB. Furthermore, the obtained SSIM values
455 as opposed to PSNR values provide better validation of our proposed content-
aware algorithm. For instance, for 20 users, the SSIM values for MLWDF and
Extended MLWDF are recorded as 0.945 and 0.94, respectively. The obtained
PSNR and SSIM values correspond to the subjective validation carried out
in [43]. Their subjective analysis indicated that PSNR less than 29 dB, and
460 SSIM lower than 0.9 are not clinically favourable for medical video streaming
application. Furthermore, a significant improvement can be seen in PSNR and
SSIM of up to 38 dB and 0.98 respectively, when the network is less congested.
It is worth mentioning, PSNR metric does not correlate well with the human
visual system and therefore SSIM metric has been adopted as a full-reference
465 objective video quality assessment metric. In addition, studies have shown that
SSIM is a good indicator of user's perception of video quality [4].

5.2. Discussion

Priority based resource allocation is a widely implemented method in wireless
transmission. Unequal error protection strategies for data transmission is a pop-
470 ular used method where unequal protection is provided to the bitstream based
on their importance. For instance, in [29], an unequal protection strategy based
on the motion information of the video bitstreams was presented. Similarly, the
authors in [44] presented a priority based time slot allocation for medical data
transmission based on the criticality of the data being transmitted. Similar to
475 such prioritisation strategies, our proposed utility function provides a strategy
for prioritising packets based on their temporal complexity.

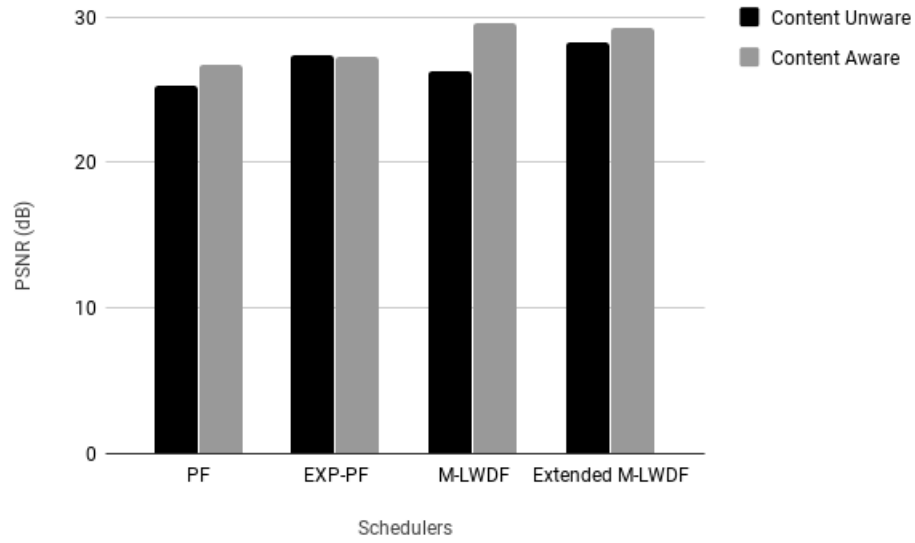

Figure 6: Average PSNR obtained after transmission for the schedulers used with and without the proposed content-aware utility function.

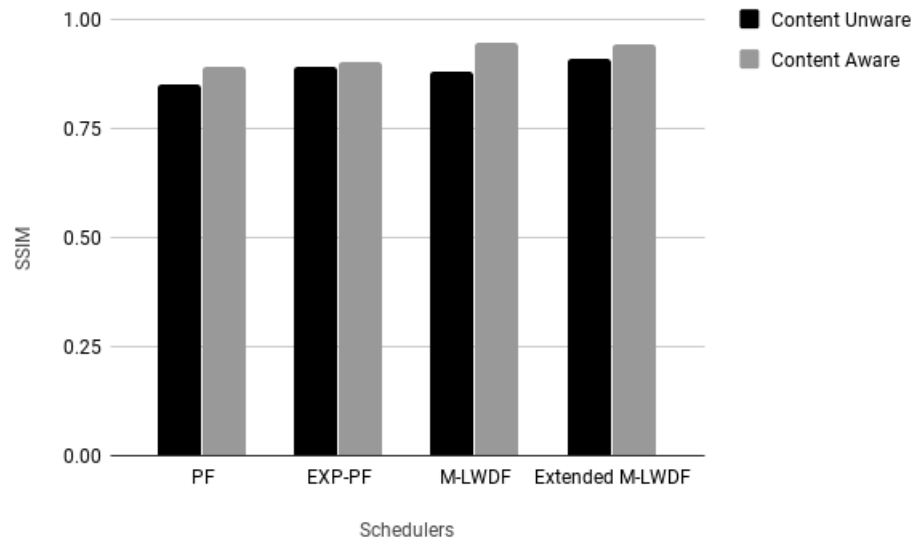

Figure 7: Average SSIM obtained after transmission for the schedulers used with and without the proposed content-aware utility function.

The results of the simulations carried out in this study showed that applying the proposed utility function helps improving the performance of the packet schedulers considered in our tests. The performance gain is particularly obtained
480 in terms of reduced packet delay and improved PSNR and SSIM. Therefore, there is gain in both QoS (packet delay) and video quality (PSNR and SSIM) performance.

The approach of prioritising packets based on their TC provides higher priority to packets belonging to a frame which has a higher TC in the buffer. A high
485 TC indicates higher level of motion activities in the frame and also is a measure of amount of changes between two successive frames. Since such packets belonging to high TC frames represent higher complexity information, losing those packets may have higher influence on the received video quality. Therefore, by prioritising such packets, the probability of losing high TC packets is
490 reduced and hence increases the chances of improving the received video quality when compared to unaware approach. The results of our simulation studies illustrate the improved performance achieved in terms of PSNR and SSIM by applying the utility function on the schedulers. In particular, it can be seen that PF and M-LWDF schedulers show higher gain of up to 2 dB and 0.05 in the
495 average PSNR and SSIM for the simulation study, respectively. A limitation of the tests conducted is that, while impairing the transmitted sequences, the packet drops were carried out assuming a memoryless erasure channel. Future extension to the work will consider the channel memory for packet dropping in order to improve the accuracy of the results.

500 The proposed utility function provides QoS gain in terms of improved packet delay performance. The results in Figure 4 illustrate the decrease in average packet delays of the simulations in our study, especially for high number of users. The improved delay performance could be attributed to the priority scheme adopted by the application of the proposed utility function. The scheduler with
505 the help of the utility function transmits the more important packets such as the ones belonging to I frame or the ones to the frame with higher TC. These packets

belong to frames which have higher bitrate or represent "higher information" and are also important for faster decoding at the receiver side. The priority to these packets implies higher bitrate frame packets are served with better resources
510 and hence makes it possible for them to leave the transmission buffer early and reaching the receiver quicker when compared to scheduling without the utility function, thereby reducing the average packet delay of the transmission.

The gains in packet delay performance and PSNR and SSIM obtained can help improving the QoS and QoE of the telemedicine system. Improved packet delay
515 performance is especially significant in real time applications such as live consultations and broadcasting for educational purposes. In emergency scenarios, packet delays could be an obstacle for treatment preparation, hence reducing packet delay is important. Further, prioritising packets belonging to higher impact frames such as I frames or high TC frames, reduces the probability of packet
520 dropping of such packets and thereby reduce the impact on video quality. In telemedicine applications, video quality is crucial for diagnostic purposes, hence good quality video is a priority. The proposed utility function enables achieving better received video quality when compared to content-unaware scheduling approach.

525 **6. Conclusion**

In this paper, a content-aware packet scheduling approach for medical ultrasound videos is proposed. The contribution of this work is a utility function based on the temporal complexity of the video frames. The utility function is used with four schedulers to prioritise the video packets based on their TC
530 and type of frame (I frame). The results showed that the utility function improves the packet delay performance obtained in our simulation when compared with content-unaware approach. Further, gains in average PSNR and SSIM are also observed in the received video quality. Research on content-aware packet

scheduling for telemedicine applications is limited and our work contributes to-
535 wards addressing this research gap.

References

- [1] ITU-T Recommendation, E.800, Definitions of terms related to quality of service, Tech. rep., International Telecommunication Union (2008).
- [2] Z. N. Li, M. S. Drew, J. Liu, Fundamentals of Multimedia, Springer, 2004.
- 540 [3] Z. Wang, A. C. Bovik, H. R. Sheikh, E. P. Simoncelli, Image quality assessment: from error visibility to structural similarity, *IEEE Transactions on Image Processing* 13 (4) (2004) 600–612.
- [4] M. Razaak, M. Martini, K. Savino, A study on quality assessment for medical ultrasound video compressed via HEVC, *IEEE Journal of Biomedical and Health Informatics* 18 (5) (2014) 1552–1559.
545
- [5] K. Seshadrinathan, R. Soundararajan, A. Bovik, L. Cormack, Study of subjective and objective quality assessment of video, *IEEE Transactions on Image Processing* 19 (6) (2010) 1427–1441.
- [6] Y. Chen, K. Wu, Q. Zhang, From QoS to QoE: A Tutorial on Video Quality Assessment, *IEEE Communications Surveys & Tutorials* 17 (2) (2014)
550 1126–1165.
- [7] G. Liebl, H. Jenkac, T. Stockhammer, C. Buchner, Radio link buffer management and scheduling for wireless video streaming, *Telecommunication Systems* 30 (1-3) (2005) 255–277.
- 555 [8] P. Pahalawatta, R. Berry, T. Pappas, A. Katsaggelos, Content-aware resource allocation and packet scheduling for video transmission over wireless networks, *IEEE Journal on Selected Areas in Communications* 25 (4) (2007) 749–759.

- [9] S. Karachontzitis, T. Dagiuklas, L. Dounis, Novel cross-layer scheme for
560 video transmission over LTE-based wireless systems, in: IEEE International Conference on Multimedia and Expo (ICME), 2011, pp. 1–6.
- [10] R. Perera, A. Fernando, T. Mallikarachchi, H. K. Arachchi, M. Pourazad, QoE aware resource allocation for video communications over LTE based mobile networks, in: 10th International Conference on Heterogeneous Net-
565 working for Quality, Reliability, Security and Robustness, Rhodes, Greece, 2014, pp. 63–69.
- [11] X. Ji, J. Huang, M. Chiang, G. Lafruit, F. Catthoor, Scheduling and resource allocation for SVC streaming over OFDM downlink systems, IEEE Transactions on Circuits and Systems for Video Technology 19 (10) (2009)
570 1549–1555.
- [12] N. Khan, M. Martini, Z. Bharucha, Quality-aware fair downlink scheduling for scalable video transmission over LTE systems, in: IEEE Conf. on Signal Processing Advances in Wireless Communications (SPAWC), Cesme, Turkey, 2012.
- 575 [13] F. Li, D. Zhang, L. Wang, Packet importance based scheduling strategy for H.264 video transmission in wireless networks, Multimedia Tools and Applications (2014) 1–17.
- [14] F. Li, G. Liu, L. He, A low complexity algorithm of packet scheduling and resource allocation for wireless VoD systems, IEEE Transactions on
580 Consumer Electronics 56 (2) (2010) 1057–1062.
- [15] Y. Zhang, G. Liu, Fine granularity resource allocation algorithm for video transmission in orthogonal frequency division multiple access system, IET Communications 7 (13) (2013) 1383–1393.
- 585 [16] N. Khan, M. G. Martini, QoE-driven multi-user scheduling and rate adaptation with reduced cross-layer signaling for scalable video streaming over

LTE wireless systems, *EURASIP Journal on Wireless Communications and Networking*, 2016.

- [17] T. Ghalut, H. Larijani, A. Shahrabi, QoE-aware optimization of video stream downlink scheduling over LTE networks using RNNs and genetic
590 algorithm, *Procedia Computer Science* 94 (2016) 232–239.
- [18] T. Zhao, Q. Liu, C. W. Chen, QoE in video transmission: A user experience-driven strategy, *IEEE Communications Surveys & Tutorials* 19 (1) (2017) 285–302.
- [19] L. Qiao, P. Koutsakis, Adaptive bandwidth reservation and scheduling for
595 efficient wireless telemedicine traffic transmission, *IEEE Transactions on Vehicular Technology* 60 (2) (2011) 632–643.
- [20] Y. Zhang, N. Ansari, H. Tsunoda, Wireless telemedicine services over integrated IEEE 802.11/WLAN and IEEE 802.16/WiMAX networks, *IEEE Wireless Communications* 17 (1) (2010) 30–36.
- 600 [21] S. Cicalo, M. Mazzotti, S. Moretti, V. Tralli, M. Chiani, Multiple video delivery in m-health emergency applications, *IEEE Transactions on Multimedia* 18 (10) (2016) 1988–2001.
- [22] L. Anegekuh, L. Sun, E. Jammeh, I.-H. Mkwawa, E. Ifeachor, Content-based video quality prediction for HEVC encoded videos streamed over
605 packet networks, *IEEE Transactions on Multimedia* 17 (8) (2015) 1323–1334.
- [23] Y. Chen, K. Wu, Q. Zhang, From QoS to QoE: a tutorial on video quality assessment, *IEEE Communications Surveys & Tutorials* 17 (2) (2015) 1126–1165.
- 610 [24] I. U. Rehman, Medical QoS and medical QoE for ultrasound video streaming over small cell networks, Ph.D. thesis, Kingston University, London, United Kingdom (September, 2017).

- [25] M. Narwaria, W. Lin, A. Liu, Low-complexity video quality assessment using temporal quality variations, *IEEE Transactions on Multimedia*, 14 (3) (2012) 525–535.
- [26] F. Yang, S. Wan, Q. Xie, H. R. Wu, No-reference quality assessment for networked video via primary analysis of bit stream, *IEEE Transactions on Circuits and Systems for Video Technology*, 20 (11) (2010) 1544–1554.
- [27] J. S. Lappin, D. Tadin, J. B. Nyquist, A. L. Corn, Spatial and temporal limits of motion perception across variations in speed, eccentricity, and low vision, *Journal of Vision* 9 (1) (2009) 30–30.
- [28] A. Derrington, P. Lennie, Spatial and temporal contrast sensitivities of neurons in lateral geniculate nucleus of macaque., *The Journal of Physiology* 357 (1984) 219.
- [29] H. D. Pham, S. Vafi, Motion-energy-based unequal error protection for H.264/AVC video bitstreams, *Signal, Image and Video Processing* 9 (8) (2015) 1759–1766.
- [30] M. Razaak, Quality evaluation of medical ultrasound videos for e-health and telemedicine applications, Ph.D. thesis, Kingston University, London, United Kingdom (February, 2016).
- [31] ITU-T Recommendation, P.910, Subjective video quality assessment methods for multimedia applications, Tech. rep., International Telecommunication Union (2008).
- [32] M. G. Martini, Wireless broadband multimedia health services: current status and emerging concepts, in: *IEEE 19th Int. Sym. on Personal, Indoor and Mobile Radio Commun. - PIMRC*, Nantes, France, 2008, pp. 1–6.
- [33] M. G. Martini, L. Iacobelli, C. Bergeron, C. T. Hewage, G. Panza, E. Piri, J. Vehkaperä, P. Amon, M. Mazzotti, K. Savino, et al., Real-time multimedia communications in medical emergency-the concerto project solution, in:

- 640 Engineering in Medicine and Biology Society (EMBC), 2015 37th Annual
International Conference of the IEEE, IEEE, 2015, pp. 7324–7327.
- [34] M. G. Martini, R. S. Istepanian, M. Mazzotti, N. Y. Philip, Robust mul-
tilayer control for enhanced wireless telemedical video streaming, *IEEE*
Trans. Mobile Comput. 9 (1) (2010) 5–16.
- 645 [35] R. S. Istepanian, Y.-T. Zhang, Guest editorial introduction to the special
section: 4G health the long-term evolution of m-health, *IEEE Transactions*
on information technology in biomedicine 16 (1) (2012) 1–5.
- [36] R. S. Istepanian, N. Y. Philip, M. G. Martini, Medical QoS provision based
on reinforcement learning in ultrasound streaming over 3.5 G wireless sys-
650 tems, *IEEE Journal on Selected Areas in Communications* 27 (4) (2009)
566–574.
- [37] G. Piro, L. A. Grieco, G. Boggia, F. Capozzi, P. Camarda, Simulating
LTE cellular systems: an open source framework, in: *IEEE Transactions*
on Vehicular Technology, Vol. 60, 2011, pp. 498–513.
- 655 [38] L. Qiao, P. Koutsakis, Guaranteed bandwidth allocation and QoS support
for mobile telemedicine traffic, in: *IEEE Sarnoff Symposium*, 2008, pp. 1–5.
- [39] J. G. Choi, S. Bahk, Cell-throughput analysis of the proportional fair sched-
uler in the single-cell environment, *IEEE Transactions on Vehicular Tech-*
nology 56 (2) (2007) 766–778.
- 660 [40] P. Ameigeiras, J. Wigard, P. Mogensen, Performance of the M-LWDF
scheduling algorithm for streaming services in HSDPA, in: *IEEE conference*
on Vehicular Technology, 2004, pp. 999–1003.
- [41] M. M. Nasralla, M. G. Martini, A downlink scheduling approach for balanc-
ing QoS in LTE wireless networks, in: *IEEE 24th International Symposium*
665 on Personal Indoor and Mobile Radio Communications (PIMRC), London,
United Kingdom, 2013, pp. 1571–1575.

- [42] A. Khan, L. Sun, E. Ifeachor, Content clustering based video quality prediction model for MPEG4 video streaming over wireless networks, in: IEEE International Conference on Communications, 2009, pp. 1–5.
- 670 [43] I. U. Rehman, N. Y. Philip, M. M. Nasralla, A hybrid quality evaluation approach based on fuzzy inference system for medical video streaming over small cell technology, in: IEEE 18th International Conference on e-Health Networking, Applications and Services (Healthcom), 2016, pp. 1–6.
- 675 [44] S. Misra, S. Sarkar, Priority-based time-slot allocation in wireless body area networks during medical emergency situations: An evolutionary game-theoretic perspective, IEEE Journal of Biomedical and Health Informatics 19 (2) (2015) 541–548.