

**UWL REPOSITORY**  
**repository.uwl.ac.uk**

Investigation of the effectiveness of dowels at the interface between reinforced concrete and ultra high performance fiber reinforced concrete

Paschalis, Spyridon and Lampropoulos, Andreas (2021) Investigation of the effectiveness of dowels at the interface between reinforced concrete and ultra high performance fiber reinforced concrete. In: International Conference on Concrete Sustainability, 8-10 September 2021, Prague, Czech Republic.

10.14311/APP.2022.33.0452

**This is the Accepted Version of the final output.**

**UWL repository link:** <https://repository.uwl.ac.uk/id/eprint/8230/>

**Alternative formats:** If you require this document in an alternative format, please contact: [open.research@uwl.ac.uk](mailto:open.research@uwl.ac.uk)

**Copyright:**

Copyright and moral rights for the publications made accessible in the public portal are retained by the authors and/or other copyright owners and it is a condition of accessing publications that users recognise and abide by the legal requirements associated with these rights.

**Take down policy:** If you believe that this document breaches copyright, please contact us at [open.research@uwl.ac.uk](mailto:open.research@uwl.ac.uk) providing details, and we will remove access to the work immediately and investigate your claim.

# **Investigation Of The Effectiveness Of Dowels At The Interface Between Reinforced Concrete And Ultra High Performance Fiber Reinforced Concrete**

**Dr Spyridon A Paschalis<sup>1\*</sup> , Dr Andreas P Lampropoulos<sup>2</sup>**

<sup>1\*</sup> School of Engineering and Computing, University of West London, UK

<sup>2</sup> School of Environment and Technology, University of Brighton, UK

**[Spyros.Paschalis@uwl.ac.uk](mailto:Spyros.Paschalis@uwl.ac.uk)**

**Abstract.** Ultra-High Performance Fiber Reinforced Concrete (UHPFRC) is a material with unique properties in tension and compression and high energy absorption in the post-cracking region. The superior performance of UHPFRC allows the construction of thin elements with high strength and ductility. A promising application of UHPFRC is for strengthening of existing Reinforced Concrete (RC) structures. In the present study, UHPFRC layers have been applied for the strengthening of full-scale RC beams. For the improvement of the UHPFRC-to-RC interface connection, dowels have been placed in addition to the roughening of surface of the initial beam and the effectiveness of this technique has been evaluated. Flexural tests have been conducted and the interface slips have been recorded in addition to the load-mid span deflections and the load carrying capacity. The results showed that the dowels resulted in better bonding at the interface and delayed the formation of the cracks in the post elastic phase with lower values of slips and subsequent higher load carrying capacity. The main conclusion of this study is that the addition of dowels at the UHPFRC-to-RC interfaces is a technique which should be considered when UHPFRC layers are used for the structural upgrade of existing RC structures.

## **1. Introduction**

The safety of the existing structures is of paramount importance especially in case of old substandard structures or structures damaged by earthquakes or other accidental actions. Currently, there are various methods for the strengthening of existing structures. However, many of these techniques have significant drawbacks such as difficulties during the application process, high cost, duration of the construction process and disturbance on the occupancy. Research should now focus on the development of new techniques using new high performance materials. The present research focus on the application of Ultra High Performance Fiber Reinforced Concrete (UHPFRC) for the strengthening of reinforced concrete (RC) beams.

The unique properties of UHPFRC have been investigated in a number of studies [1-4]. At present there are limited studies on the investigation of the effectiveness of UHPFRC as strengthening material. Habel et al. [5] investigated analytically the performance of composite UHPFRC-concrete elements with the assumption of monolithic connection at the interface. Bruhwiler and Denarie [6] applied UHPFRC in rehabilitation applications, such as; road bridge, a bridge pier and industrial floor. Lampropoulos et al. [7] presented a numerical investigation on the performance of UHPFRC for the flexural strengthening of RC beams and the effectiveness of the technique was highlighted. Paschalis et al. [8] presented an experimental and numerical investigation on the performance of UHPFRC for the flexural strengthening of full-scale RC beams. In this study [8] it was found that the UHPFRC layers can delay the formation of the cracks and increase the stiffness of the strengthened members. The addition of steel bars to the layers resulted in a significant increment of the load carrying capacity of the examined specimens. Improved bonding conditions were observed at the UHPFRC-to-concrete interfaces as compared to conventional concrete-to-concrete interfaces. However, in this study it was found that the slips at the interface were not negligible. On the contrary, high values of slip at the interface recorded in the post elastic region.

In all studies to date, the use of dowels has been eliminated mainly due to the improved connection at the interface between UHPFRC and concrete in the elastic region. However, previous studies have proven that even if the connection is improved, there are interface slips and local interface failure may occur in the post-elastic region of strengthened elements [8]. The present research aims to examine the crucial topic of the effectiveness of dowels at the interface between UHPFRC and RC, which has not been investigated to date. In the present investigation, full scale RC beams strengthened with UHPFRC layers, with and without the use of dowels, and the effectiveness of the different interface conditions have been evaluated.

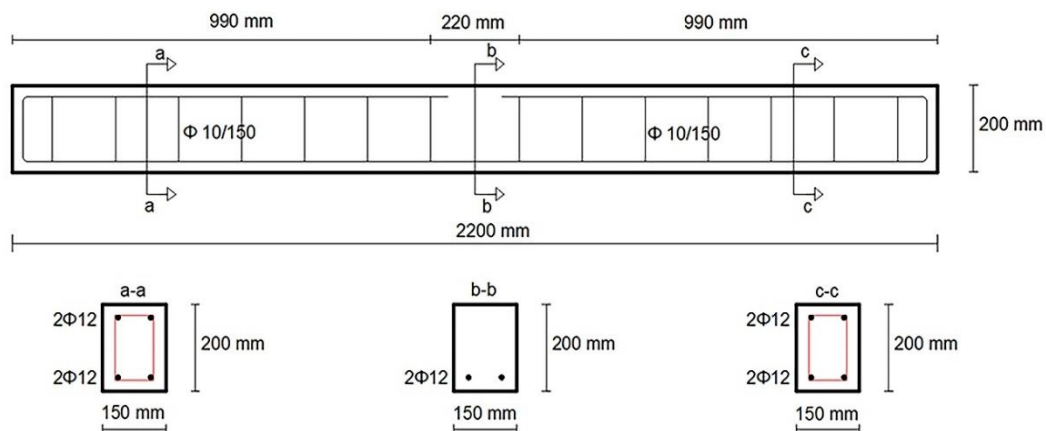
## 2. Experimental Program

In the present study, six RC beams have been examined. Two beams were used as control beams without any retrofit, two beams were strengthened with UHPFRC layers where interface roughening was only applied, and another two beams were strengthened with UHPFRC layers and dowels were used in addition to the interface roughening (Table 1).

**Table 1** Examined Beams

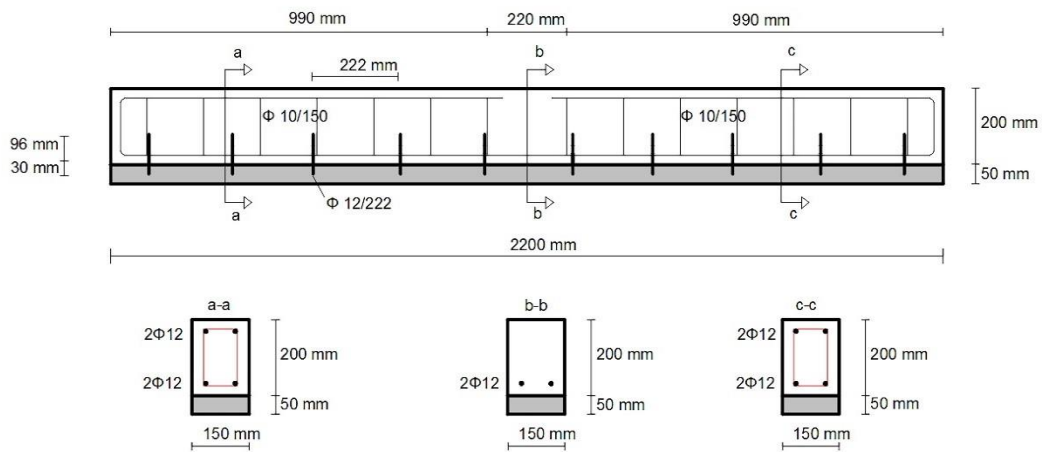
Beam	Strengthening Technique
P1	Control beam
P2	Control beam
U1	UHPFRC layer
U2	UHPFRC layer
D1	UHPFRC layer and dowels
D2	UHPFRC layer and dowels

The beams were reinforced with two steel bars grade B 500C, with a diameter of 12 mm at the tensile side. Also, shear links  $\Phi 10/150$  mm were along the length of the beam to prevent shear failure (Figure 1).

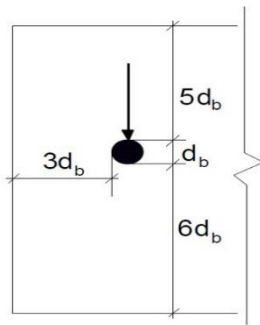


**Figure 1** Geometry and reinforcement of the RC beams

The layers had a thickness of 50 mm and were cast along the whole length of the tensile side of the beams. For the dowels, ribbed steel bars with a length of 126 mm, diameter 12 mm were used at a spacing of 222 mm (Figure 2). The design of the dowels was based on the Greek Retrofitting Code [9]. In Figure 2, the geometry and reinforcement of the strengthened beam with layers and dowels and the minimum required cover for the dowels, as suggested on the Greek Code for Interventions [9], are presented.



(a)



(b)

**Figure 2** a) Geometry and reinforcement of the strengthened beam with layers and dowels b) Minimum required cover for the dowels based on the Greek Code for Interventions

### 3. Preparation of the Specimens

For the preparation of the UHPFRC, silica sand with a maximum particle size of 500  $\mu\text{m}$  was used together with Microsilica, Ground Granulated Blast Furnace Slag (GGBS) and cement class 52.5 R type I. In addition, steel microfibers with a length of 13 mm and a diameter of 0.16 mm were incorporated in the mixture. In the present study a fiber content of 3 Vol-% was selected. The mixture design is presented in Table 2.

**Table 2** The mixture design for the preparation of UHPFRC

Material	Quantity (kg/m <sup>3</sup> )
Cement	620
GGBS	434

Silica fume	140
Silica Sand	1051
Superplasticizer	59
Water	185
Steel fibers	235.5

For the roughening of the interface between UHPFRC and RC a pistol grip needle scaler was used and the specimens were roughened to a depth of 2-2.5 mm. To quantify the surface texture, the sand patch method was used. Once the desired roughening depth was achieved and the surface was ready, the beams were drilled, using an impact drill, and the dowels were placed in position.

For the connection of the dowels with the beams, a thixotropic structural two-part adhesive, based on a combination of epoxy resins and special filler was used. In Figure 3, the construction of the dowels in the initial beam prior to the casting of the layer is presented.

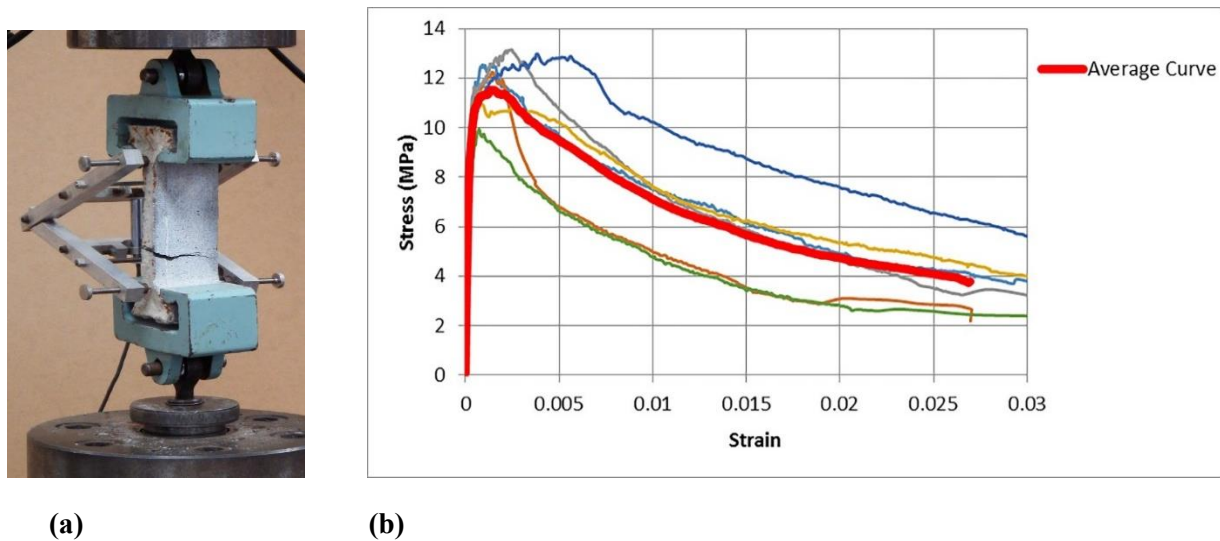


**Figure 3** Beam with dowels ready for casting

#### **4. Properties of the materials**

Three 100 mm side cubes were tested to identify the compressive strength of the conventional concrete of the initial beams and the UHPFRC of the additional layers. The compressive tests were conducted following the BS EN 12390-3:2009 [10]. All the cubes were tested at the same time with the flexural tests of the strengthened elements and specifically four months after the casting of the initial beams and two months after the casting of the UHPFRC layers.

The average compressive strength of three concrete cubes was 30.9 MPa, while the standard deviation was found to be equal to 2.34 MPa. The average compressive strength of the UHPFRC on the other hand, was found to be equal to 136.5 MPa and the standard deviation was 5.5 MPa. The tensile properties of UHPFRC were evaluated using 5 dog-bone shaped specimens. In Figure 4a, the dog bone testing setup is presented, while the tensile stress-strain results are illustrated in Figure 4b.



**Figure 4** a) Dog bone specimen b) Experimental results from the direct tensile testing of UHPFRC

From the average curve, the maximum stress was found to be equal to 11.5 MPa and the modulus of elasticity was calculated equal to 51 GPa.

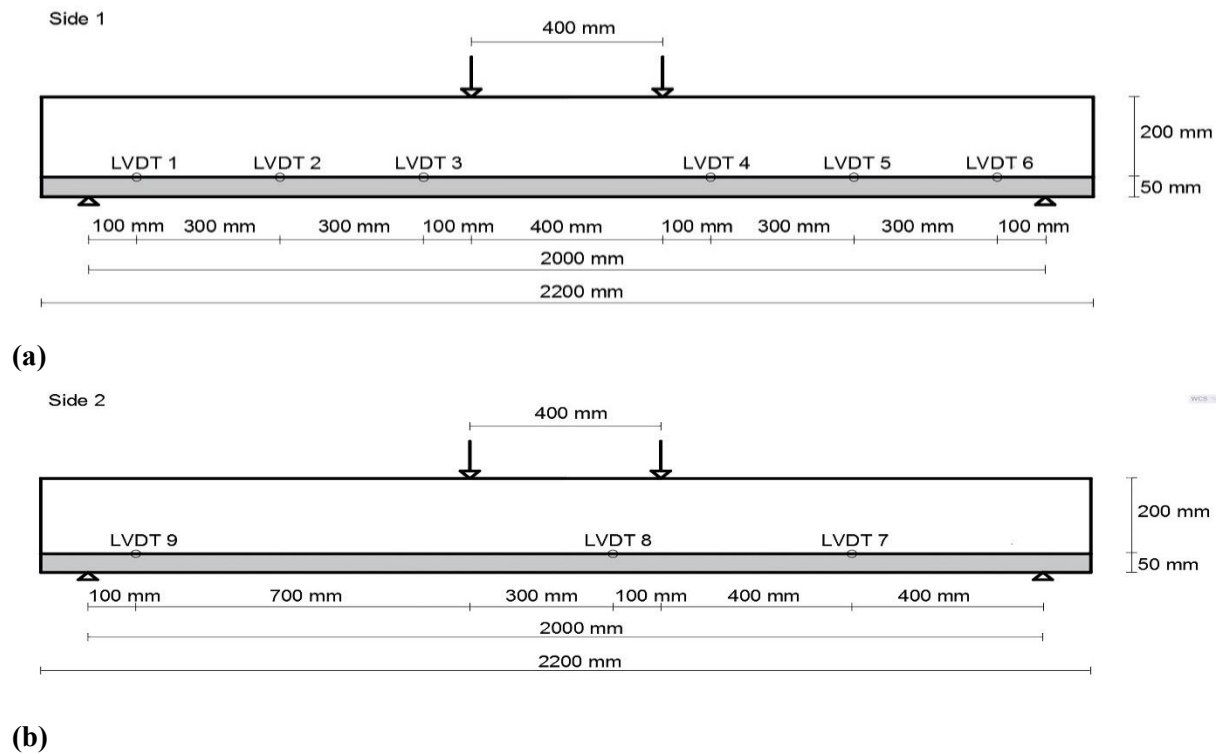
### 5. Testing of the beams

The examined beams, were tested under a four-point loading test with a displacement rate of 0.008 mm/sec.



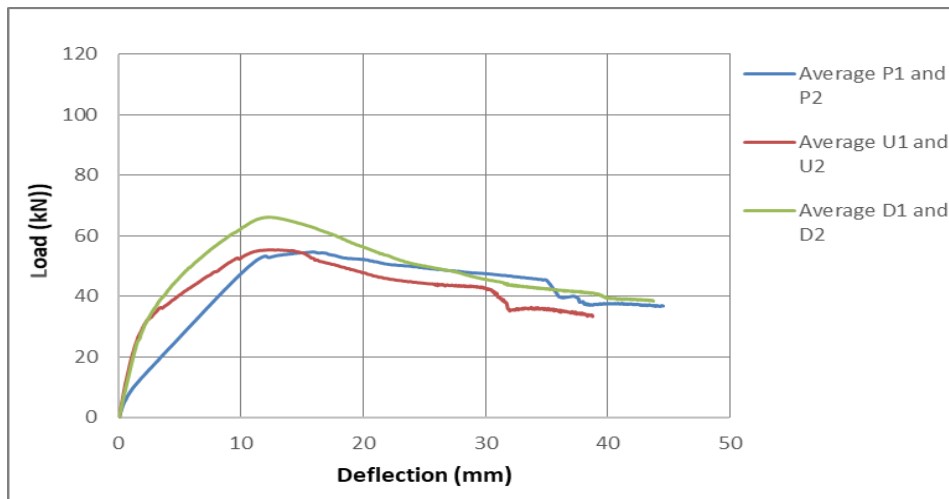
**Figure 5** Experimental setup for the testing of beams

During the testing, the slips at the interface between UHPFRC and RC were recorded using nine LVDTs in total. As can be seen in Figures 6a and 6b, 6 LVDTs were placed on side 1 of the beam, while 3 LVDTs were placed at the other side (side 2) to validate the results obtained from side 1.



**Figure 6** a) Positions of the LVDTs for the measurement of slips on side 1 b) positions of the LVDTs for the measurement of slips on side 2

The average load-deflection results for the control beams, the strengthened beams with UHPFRC layers and the strengthened beams with UHPFRC layers and dowels at the interface are presented in Figure 7.



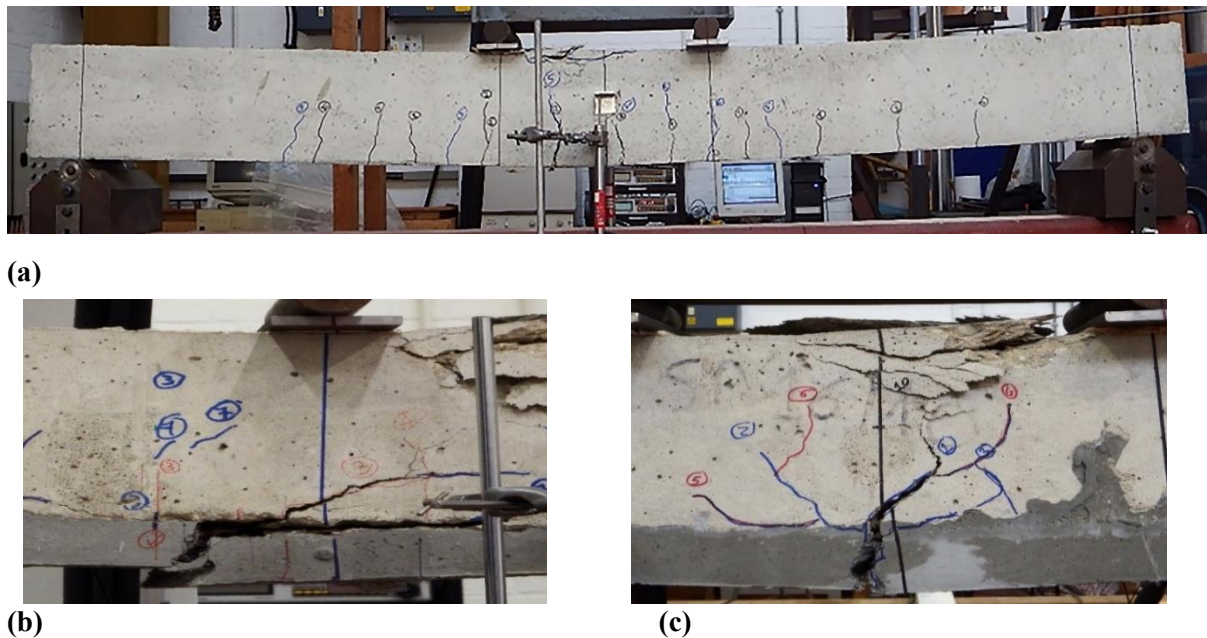
**Figure 7** Average load-deflection results

As indicated in Figure 7, the strengthening with UHPFRC layers without dowels (U1 and U2) resulted to a significant increment of the stiffness of the strengthened elements (134%), while the load capacity was also slightly increased. The addition of dowels at the interface on the other hand (specimens D1 and D2), apart from an increase in the stiffness, resulted to a significant increment of the load capacity of the strengthened specimens, namely 21.5 %.



The failure mode of the control beams P1 and P2 was identical and characterized by a single crack in the middle of the span (Figure 8a). Similar was the failure mode of the beams strengthened with UHPFRC layers without dowels (U1 and U2). However, during of the testing of beam U1, a local de-bonding at the interface was initiated when the load reached a value of 48 kN (Figure 9b). After post testing inspection of this specimen it was noticed that the roughness depth was lower in this area and therefore this is attributed to imperfections during the preparation process. On the contrary, the bonding at the interface of beam U2 was effective. Beams D1 and D2, which were strengthened with UHPFRC layers and dowels failed due to flexural cracks in the middle of the span length of the strengthened beams.

Figure 8c presents the failure mode of beam D1 which indicates very strong connection at the interface, attributed to the contribution of the dowels. In this case, a single crack was initially formed at the UHPFRC near the middle of the span and was propagated to the initial RC beam indicating perfect connection at the interface.



**Figure 8** a) Failure mode of beam P1 b) Local de-bonding of beam U1 c) Failure mode of beam D1

The addition of dowels (specimens D1 and D2) resulted in a delay in the formation of cracks compared to the specimens strengthened with UHPFRC layers without dowels (U1 and U2). This was obvious from the visual inspection of the beams during the testing, and was also reflected to the load-deflection results. The end of the elastic part of the load-deflection response was identified from Figure 7, and the values are presented in Table 3.

**Table 3** Load values at the end of the linear part of the load-deflection graphs

Beam	Start of Cracking (kN)
Average Plain (P1 and P2)	5
Average with Layers (U1 and U2)	15
Average with Dowels (D1 and D2)	24

From the results of Table 3 it is clear that the addition of dowels resulted in the delay of the formation of cracks and the cracking started for a value of load 60% higher compared to the beams which were strengthened without dowels.



The maximum load of beam U2, which was prepared without the use of dowels, was 56.3 kN, and slips were recorded at the positions of LVDTs 2,3,4,7 and 8. In Table 4, the interface slip values for beams U2, D1, D2 for load equal to the maximum load of U2 specimen (56.3 kN) is presented. Due to a local debonding at the interface of beam U1, the measurements of this beam were ignored.

**Table 4** Slip measurement for the beams U2, D1, D2 for value of load 56.3 kN

Position	Beam U2	Beam D1	Beam D2
LVDT 2	0.06	0.04	0.01
LVDT 3	0.11	0.01	0.19
LVDT 4	0.357	0.05	0.06
LVDT 7	0.03	0.03	0
LVDT 8	0.18	0.14	0.01

The result of Table 4 indicate that the recorded values of slip at beams D1 and D2 (in almost all the examined positions) were significantly lower compared to the slips at beam U2 where dowels were not used. The failure of beam D2 commenced close to the position of LVDT 3, which may have affected the measurements at this position.

The results of the present investigation indicate that the use of dowels at the UHPFRC-to-RC interfaces can result in better bonding, reducing the slip values and delaying the formation of the cracks in the post-elastic phase. This has as a result the increment of the load carrying capacity and therefore this technique should be considered for the structural upgrade of existing load bearing RC elements.

## 6. Conclusions

In the present study the effectiveness of dowels at the interface between UHPFRC and RC has been investigated. Six identical full-scale RC beams have been examined in total. Two beams were used as control beams without any retrofit, two beams were strengthened with UHPFRC layers with a roughened interface only and another two beams were strengthened with UHPFRC layers and dowels were used in addition to the interface roughening. During the testing of the beams both the load carrying capacity and the slips at the interface were recorded.

Based on the results of the present investigation the following conclusions can be drawn:

- Dowels at the interface between UHPFRC and RC result in improved bonding, with lower slip values and therefore significantly reduced risk of de-bonding.
- The addition of dowels at the interface delays the formation of cracks at the strengthened beams.
- The addition of dowels at the interface leads to increased load carrying capacity of the strengthened beams. The experimental results of the present study indicated an increase of 21.5% of the load carrying capacity when dowels were used at the interface. The respective increase without the use of mechanical connectors was 1.5%.

## 7. References

- [1] Ferrara L, Ozyurt N and Di Prisco M 2011 High mechanical performance of fibre reinforced cementitious composites: the role of "casting-flow induced" fibre orientation, *Materials and Structures* **44** (1) 109-128
- [2] Paschalis S, Lampropoulos A 2017 Fiber content and curing time effect on the tensile characteristics of Ultra High Performance Fiber Reinforced Concrete (UHPFRC) *Structural Concrete* **18** 577-588
- [3] Paschalis S, Lampropoulos A 2016 Ultra High Performance Fiber Reinforced Concrete Under Cyclic Loading *ACI Materials Journal* **113** (4) 419-427

***Fib International Conference on Concrete Sustainability, 8-10 September 2021, Prague, Czech Republic***

- [4] Kang S T, Kim J K 2011 The relation between fiber orientation and tensile behavior in an Ultra High Performance Fiber Reinforced Cementitious Composites (UHPFRCC) *Cement and Concrete Research*, **41**(10) 1001-1014
- [5] Habel K , Denarie E, Bruhwiler E 2006 Structural response of elements combining Ultra- High-Performance Fiber Reinforced Concretes and Reinforced Concrete *Journal of Structural Engineering* **132** (11) 1793-1800
- [6] Bruhwiler E, Denarie E 2008 Rehabilitation of concrete structures using Ultra-High Performance Fibre Reinforced Concrete *The Second International Symposium on Ultra High Performance* Kassel, Germany
- [7] Lampropoulos A, Paschalis S, Tsioulou O and Dritsos S 2015 Strengthening of reinforced concrete beams using ultra high performance fibers reinforced concrete (UHPFRC), *Engineering Structures*, **106**, 370-384
- [8] Paschalis S, Lampropoulos A and Tsioulou O 2018 Experimental and numerical study of the performance of Ultra High Performance Fiber Reinforced Concrete–Reinforced Concrete for the flexural strengthening of full scale members *Construction and building materials* **186** 351-366.
- [9] Greek Organization for Seismic Planning and Protection, Greek Retrofitting Code (GRECO) 2013 Athens (in Greek)
- [10] BS EN 12390-3:2009 Testing hardened concrete-Part 3: Compressive strength of test specimens