



UWL REPOSITORY

repository.uwl.ac.uk

Development of a turn-based game using Blockchain and Smart Contracts technology

Luszczyszyn, Hubert (2022) Development of a turn-based game using Blockchain and Smart Contracts technology. In: School of Computing and Engineering Research and Industry Day 2022, 29 Jun 2022, London, United Kingdom. (Unpublished)

This is the Accepted Version of the final output.

UWL repository link: <https://repository.uwl.ac.uk/id/eprint/9204/>

Alternative formats: If you require this document in an alternative format, please contact: open.research@uwl.ac.uk

Copyright:

Copyright and moral rights for the publications made accessible in the public portal are retained by the authors and/or other copyright owners and it is a condition of accessing publications that users recognise and abide by the legal requirements associated with these rights.

Take down policy: If you believe that this document breaches copyright, please contact us at open.research@uwl.ac.uk providing details, and we will remove access to the work immediately and investigate your claim.

Rights Retention Statement:



Abstract

- This project focuses on turn-based game development by using Blockchain and Smart Contract technology,
- The research focuses on determining advantages and disadvantages of different blockchains as well as it focuses on examining already developed games on blockchain,
- The game prototype development is described with further development aims which are delivering front-end, which is based on web 3.0 app, and moving from Ganache test-net to Ethereum Mainnet.

Smart contract interaction example

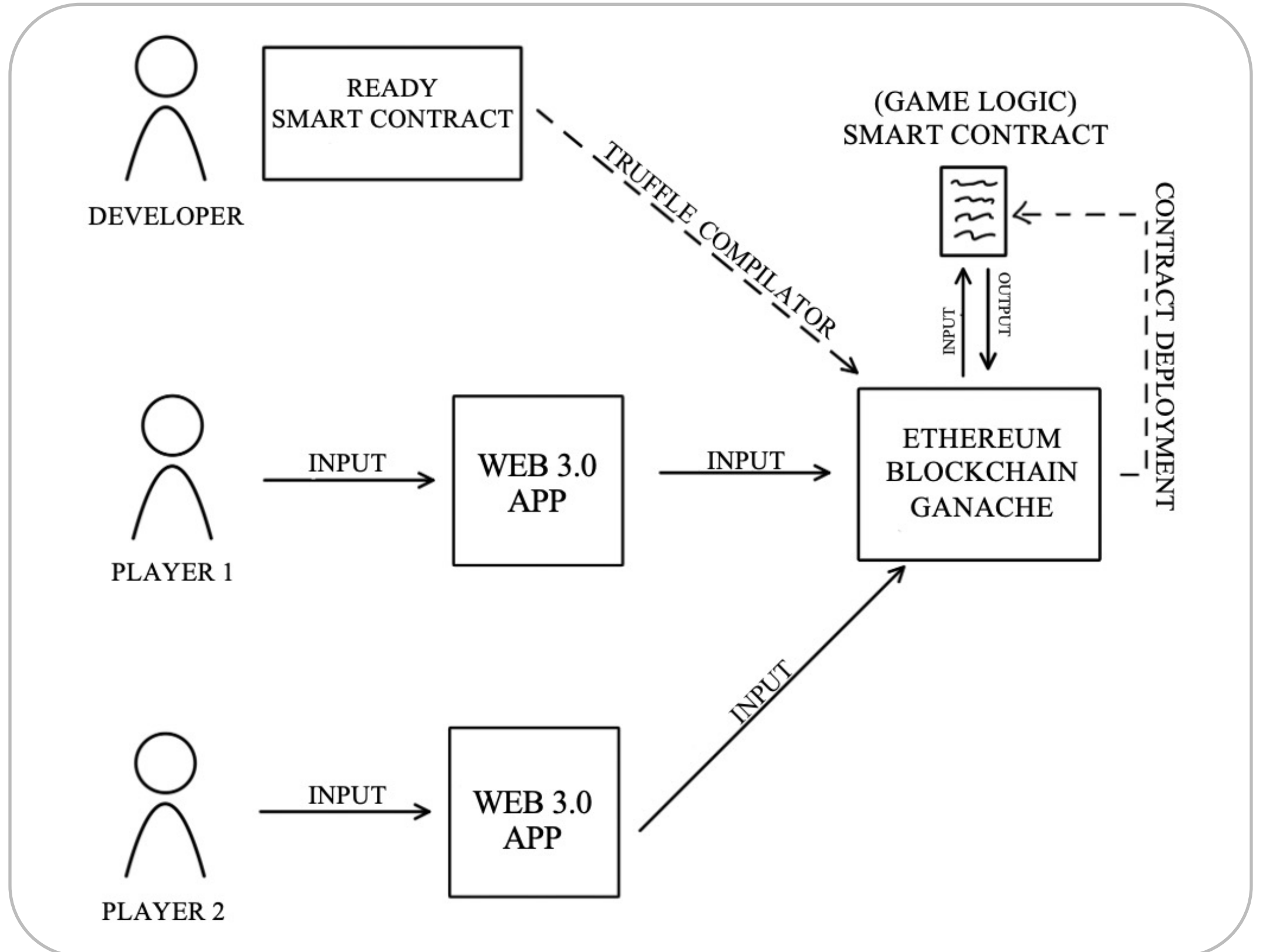

Introduction and methodology

Introduction

This poster will briefly explain the main concept of the research project with design ideas and methodologies

Methodology

- Based on project complexity, agile methodology of development has been chosen in order to ensure that project will be delivered,
- Literature research includes deep research about available blockchains and games which has been developed on these blockchains,
- The design and implementation covers development ideas and environment description.

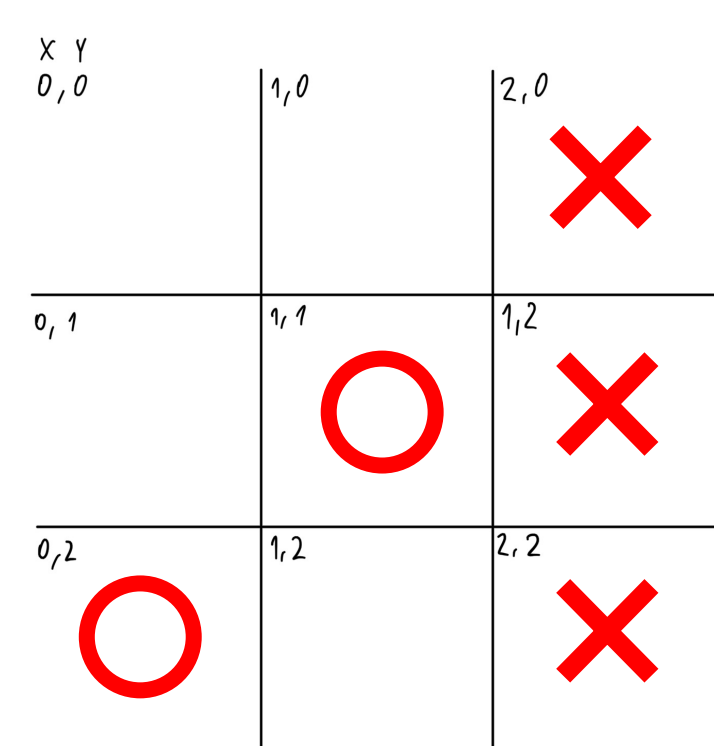
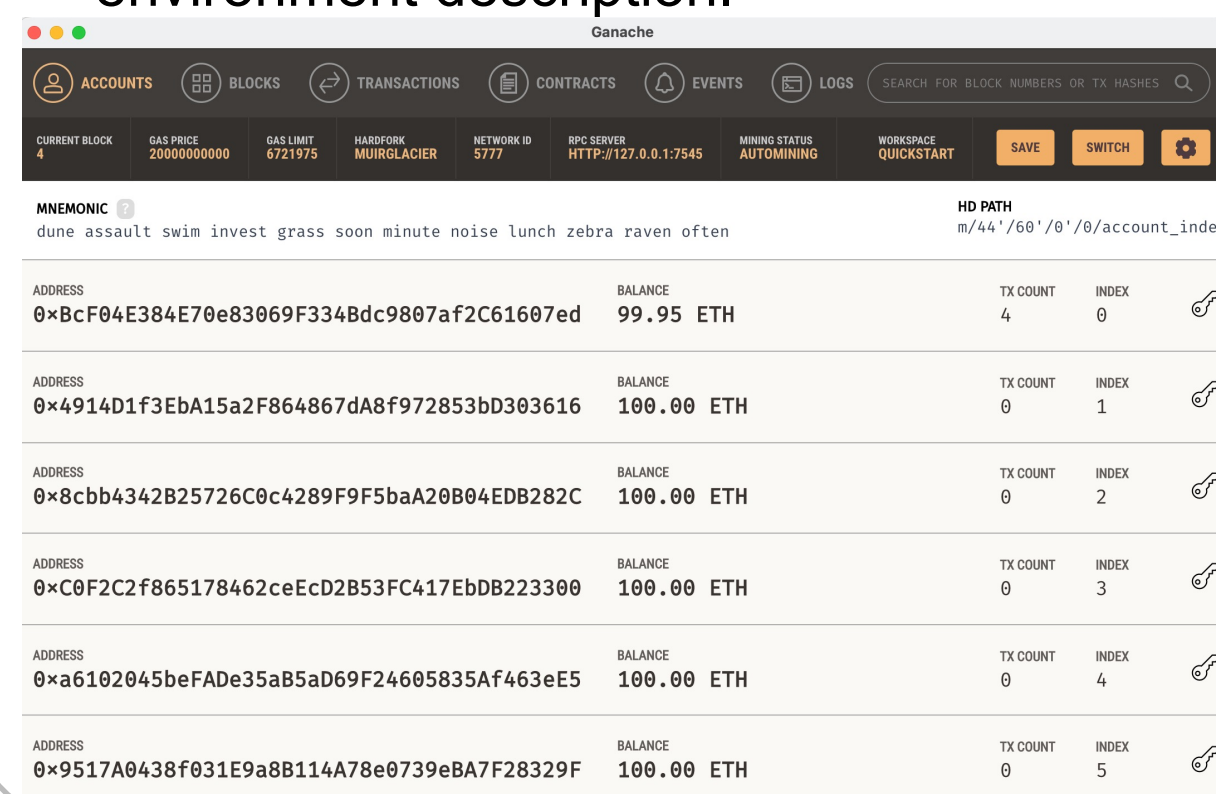

Create new game + gameplay flowchart

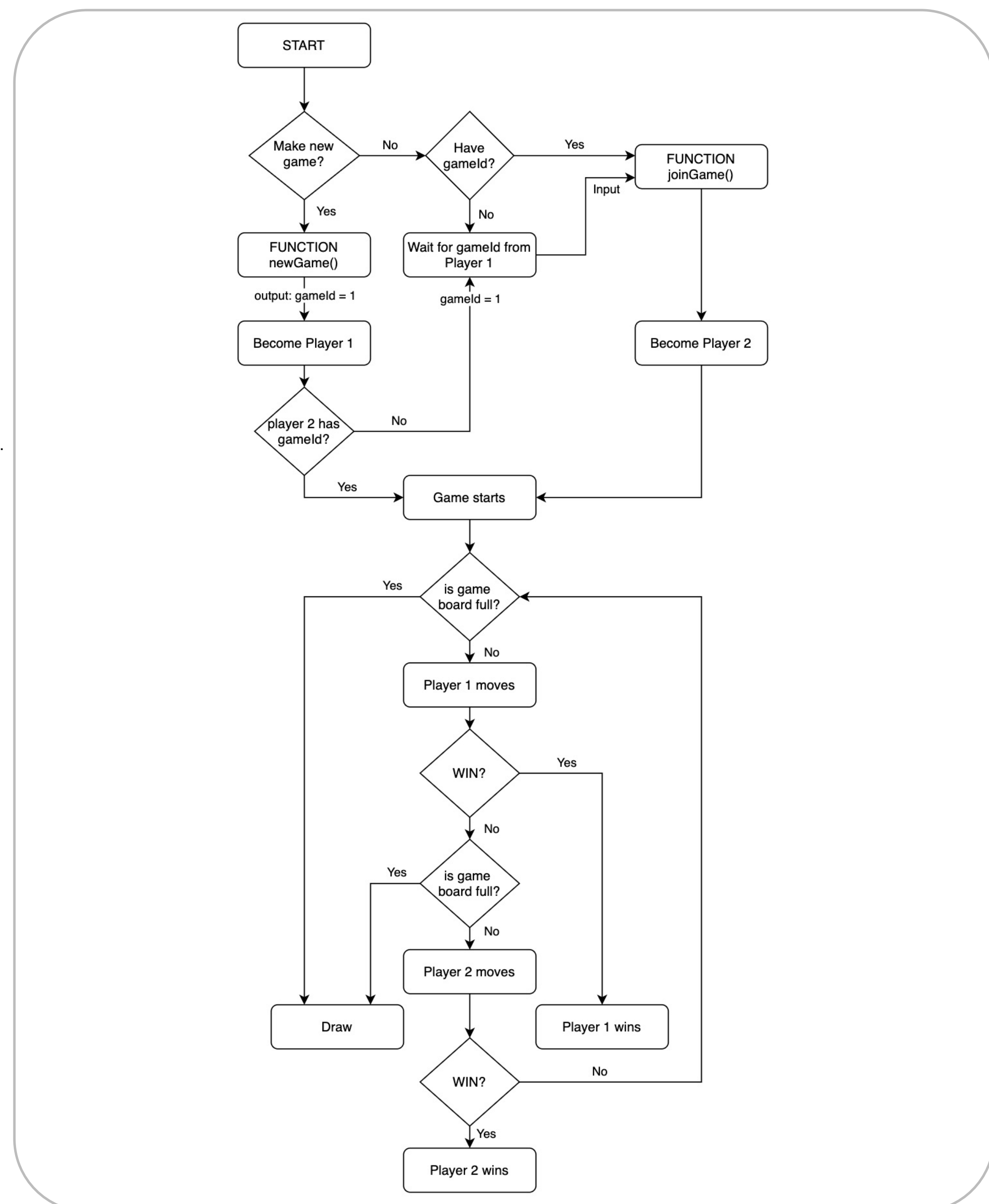

Aims and Objectives

Aims

- The main project idea is to develop working prototype of Tic-Tac-Toe game on blockchain with use of smart contracts,
- Aim for the research is to find the best blockchain for this project and examine advantages and disadvantages of the most popular ones.

Objectives

- Choose appropriate blockchain for this project
- Investigate blockchain games whitepapers
- Look for games that has game mechanics based on smart contracts
- Develop a turn-based game based on blockchain
- Critical evaluation of the game in context of cheating

Results and Conclusions

Results

- Entire game logic has been implemented in blockchain using one smart contract
- Objectives conditions has been met and based on that, Ethereum blockchain has been chosen
- Issues have been found with gas fees which are high, so it turned out that playing Tic-Tac-Toe is quite expensive,

Conclusions

At today's stage, when Ethereum 2.0 has not been fully released, gas fees will stay high due to high transaction rate. Ethereum 2.0 should be released by the end of 2022. Based on research, I came out to a conclusion that if faster blockchain pretends to be, then security is being weaker.

#	Name	Price	24h %	7d %	Market Cap	Volume(24h)
1	Bitcoin BTC	£24,220.71	+0.43%	+2.31%	£460,275,922,091	£17,647,083,862
2	Ethereum ETH	£1,442.51	+0.13%	+3.50%	£173,603,341,808	£9,851,873,815
3	Tether USD	£0.7985	+0.47%	+2.39%	£57,838,218,902	£34,218,031,859
4	USD Coin USDC	£0.7994	+0.43%	+2.38%	£42,980,208,072	£2,748,371,148
5	BNB BNB	£233.03	+0.12%	+6.60%	£37,966,779,110	£664,927,839
6	Cardano ADA	£0.5155	+2.08%	+7.51%	£17,208,131,769	£991,589,779
7	XRP XRP	£0.3207	+0.11%	+1.97%	£15,464,496,346	£754,592,324
8	Binance USD BUSD	£0.8	+0.33%	+2.42%	£14,328,132,473	£3,638,630,125
9	Solana SOL	£32.50	+2.84%	+2.46%	£11,015,847,751	£959,982,222
10	DogeCoin DOGE	£0.06392	+0.42%	+5.03%	£8,461,004,757	£210,623,760

The screenshot shows the **Etherscan Gas Tracker** interface. It displays the current gas price as **39 gwei** and provides information about the gas base, priority, and time to confirm a transaction. The interface includes a **Featured: Wallet-to-wallet instant messaging via Blockchain Chat!** and a **Next update in 6s** timer.

References

- etherscan.io. (2022) *Gas Tracker*. [online] Available at: <https://etherscan.io/gastracker> [Accessed 8 June 2022].
- Coinmarketcap.com. (2022) [online] Available at: <https://coinmarketcap.com> [Accessed 9 June 2022].